

0085214
D0194

Roller

RT 560
RT 820

Operator's Manual



Information Contained In This Manual

This manual provides information and procedures to safely operate and maintain the WACKER RT 560 and RT 820 Trench Rollers. This machine is equipped with a two-cylinder Lombardini diesel engine.

For your own safety and protection from physical injury, carefully read, understand, and observe the safety instructions described in this manual.

Always operate and maintain your machine in accordance with the instructions described in this manual. A well maintained machine will provide many years of trouble-free operation.

This book is divided into two sections:

1

General Operating Information

2

Infra-Red Remote Control Operation

Ordering Parts

A Parts Manual is available for this machine and can be ordered using P/N 85215.

Additional Engine Information

A manual for the engine was supplied with the machine at the time of its shipment from the factory. This manual provides detailed maintenance procedures for the engine.

For additional service information on the engine, order Work Shop Manual, P/N 74232.

Keep a copy of this manual with the machine. If a manual becomes lost or additional copies are desired, please contact WACKER Corporation.

This Manual covers machines with
Serial Numbers beginning:

6594, 6595

6784, 6785

FOREWORD

Identification Plate

An identification plate listing the Model Number and Serial Number is attached to each machine and is located inside on the control panel. This plate should not be removed from the machine.

Please record the information found on this plate so it will be available should the identification plate become lost or damaged. When ordering parts or requesting service information you will always be asked to specify the model and serial number of the unit.

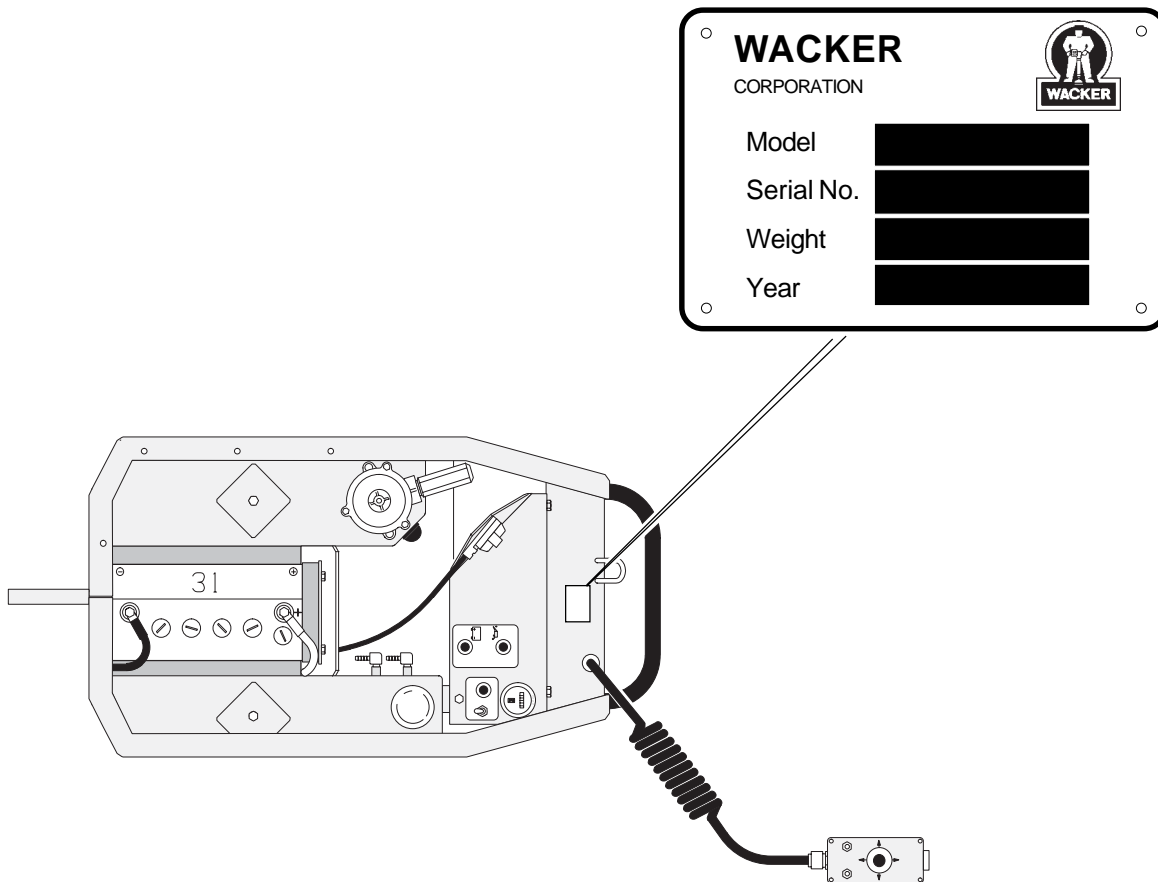

1002SD33

Serial Number

The serial number found on the identification plate is a nine digit number. The first four digits identify the specific machine model (Bill of Material). The last five numbers indicate the production sequence for that model.

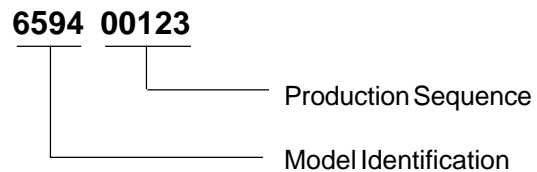

The serial number identifies your machine and will ensure that you receive the correct replacement parts.

RT560/RT820 General Operating Information

1

Table of Contents

	Page		Page
SAFETY		MAINTENANCE	
1.1 Safety Notes	1-2	1.24 Engine Fuel Delivery System	1-11
1.2 Operating Safety	1-3	1.25 New Machines	1-11
1.3 Engine Safety	1-3	1.26 Periodic Maintenance Schedule	1-11
1.4 Service Safety	1-4	1.27 Air Cleaner	1-12
TECHNICAL DATA		1.28 Engine Lubrication	1-12
1.5 Engine	1-5	1.29 Articulated Joint & Steering Cyl.	1-12
1.6 Roller	1-5	1.30 Drive Gearcase	1-13
1.7 Lubrication	1-5	1.31 Exciter	1-13
OPERATION		1.32 Engine Valve Clearance	1-13
1.8 Controls & Service Locations- Roller	1-6	1.33 Fuel Filter	1-14
1.9 Service Locations - Engine	1-7	1.34 Priming Fuel System	1-14
1.10 Before Starting	1-8	1.35 Cleaning Engine Cylinder	
1.11 Starting	1-8	Cooling Fins	1-14
1.12 Stopping	1-8	1.36 Scraper Bars	1-14
1.13 Travel	1-8	1.37 Shockmounts	1-14
1.14 Direction & Steering Control	1-8	1.38 Hydraulic Oil Requirements	1-15
1.15 Vibration	1-9	1.39 Changing Hydraulic Fluid & Filter ...	1-15
1.16 Safety Bar	1-9	1.40 Hydraulic Fluid Level	1-15
1.17 Operation on Slopes	1-9	1.41 Transporting Machine	1-16
1.18 Engine Speed.....	1-10	1.42 Lifting Machine	1-16
1.19 Engine Oil Pressure Light	1-10	1.43 Changing Drums	1-16
1.20 Charging System Light	1-10	1.44 Battery	1-17
1.21 Hour Meter	1-10	1.45 Tightening Hardware	1-17
1.22 Articulated Joint Locking Pin	1-10	1.46 Jobsite Storage	1-17
1.23 Automatic Engine Shut-off	1-10	1.47 Long Term Storage	1-17
		TROUBLESHOOTING	
		1.48 General	1-18
		1.49 Hydraulic Schematic	1-19
		1.50 Control Box Wiring	1-20
		1.51 Relay Panel and Engine Wiring	1-21
		(W/15 Amp Vibration Relay Fuse)	
		1.52 Relay Panel and Engine Wiring	1-22
		(W/O 15 Amp Vibration Relay Fuse)	

1.1 Safety Notes

This manual contains NOTES, CAUTIONS and WARNINGS which must be followed to prevent the possibility of improper service, damage to the equipment or personal injury.

Notes: *Notes appear in italics and contain additional information important to a procedure.*

CAUTION

Cautions provide information important to prevent errors which could damage machine or components.



WARNING

Warnings warn of conditions or practices which could lead to personal injury or death!

WACKER equipment is designed with user safety in mind. When properly maintained and used by trained operators in the applications for which it was intended, this machine will provide many years of safe, reliable service.

Should questions arise during the operation or service of this equipment please contact your area WACKER Customer Support Center. A complete listing of Support Centers appears on the front and rear covers of this manual.

1.2 Operating Safety

Familiarity and proper training are required for the safe operation of mechanical equipment !

Equipment operated improperly or by untrained personnel can be dangerous! Read the operating instructions and familiarize yourself with the location and proper use of all controls. Inexperienced operators should receive instruction from someone familiar with the equipment before being allowed to operate the machine.

WARNING

- Check that all safety devices and guards are in place before starting machine! **DO NOT** operate machine if any safety devices or guards are missing or inoperative.
- Disengage locking pin for the articulated joint before operating machine. The machine cannot be steered when the locking pin is engaged.
- Check that all controls are functioning properly immediately after start-up! **DO NOT** operate machine unless all controls operate correctly.
- Remain aware of changing positions and movement of other equipment and personnel on the jobsite.
- Remain in visual contact with machine at all times while operating controls.
- Remain aware of changing surface conditions and use extra care when operating over uneven ground, on hills or over coarse material. The machine could shift or slide unexpectedly.
- Use caution when operating near the edges of pits, trenches or platforms. Check to be sure ground surface is stable enough to support the weight of the machine and there is no danger of the roller sliding, falling or tipping.
- Position yourself safely when operating machine in reverse or on hills. Leave enough space between yourself and the machine so you will not be placed in a hazardous position should the machine slide or tip.

1.3 Engine Safety

Internal combustion engines present special hazards during operation and fueling !

Failure to follow the safety guidelines described below could result in severe injury or death.

WARNING

- **DO NOT** run engine indoors or in an area with poor ventilation unless exhaust hoses are used.
- **DO NOT** fill fuel tank near an open flame, while smoking or while engine is running.
- **DO NOT** fill tank in an enclosed area with poor ventilation.
- **DO NOT** touch or lean against hot exhaust pipes or engine cylinder.
- **DO NOT** operate with the fuel tank cap loose or missing.
- Keep area around hot exhaust pipes free of debris to reduce the chance of an accidental fire.

1.4 Service Safety

Poorly maintained equipment can become a safety hazard !

In order for the equipment to operate safely and properly over a long period of time periodic maintenance and occasional repairs are necessary.



WARNING

- Replace all guards and safety devices immediately after servicing.
- Turn engine off before performing maintenance or making repairs.
- Secure the articulated joint using the locking pin before lifting or jacking machine up. Machine halves could swing together unexpectedly and cause a serious injury if this is not done.
- **DO NOT** open hydraulic lines or loosen hydraulic connections while engine is running! Hydraulic fluid under pressure can penetrate the skin, cause burns, blind or create other potentially dangerous hazards. Set all controls in neutral and turn engine off before loosening hydraulic lines.
- Keep hands, feet and loose clothing away from moving parts.
- Replace all missing and hard to read decals. See Parts Manual.
- Check and tighten all external fasteners at regular intervals.
- Make sure slings, chains, hooks, ramps, jacks and other types of lifting devices are attached securely and have enough weight bearing capacity to lift or hold the machine safely. Always remain aware of the position of other people around you when lifting the machine.
- **DO NOT** modify the equipment without expressed written approval from WACKER Corporation.

1.5 Engine

Engine Type	Two cylinder, 4-cycle air cooled, diesel engine	
Engine Make	Lombardini	
Engine Model	12LD435-2 ¹	12LD475-2 ¹
Power @ 2500 rpm	Hp (kW)	16 (12)
Operating Speed	rpm	2600 ± 100
Alternator	V / Amp	12 / 14
Battery	V/ A hr/size	12 / 160 / 31
Air Cleaner	Type	Dry pleated paper element with pre-cleaner
Valve Clearance - in/ex	in.(mm)	.006 - .008 (0.15-0.20)
Fuel	Type	No.2 Diesel
Fuel Consumption	gal.(l)/hr	1.1 (4.2)
Fuel Tank Capacity	gal. (l)	5.6 (21)

¹ Refer to identification plate on engine.

1.6 Roller

		RT 560	RT 820
Overall Dimensions (l x w x h)	in (mm)	80 x 22 x 48 (2030 x 560 x 1220)	80 x 32 x 48 2030 x 820 x 1220
Operating Weight	lbs.(Kg)	2830 (1283)	2960 (1345)
Area Capacity	ft ² (m ²) / hr	7500 (690)	10900 (1016)
Inside Turning Radius	in (m)	58 (1.5)	
Low Speed	ft (m)/min.	68 (21)	
High Speed	ft (m)/min.	136 (41)	
Vibration Frequency	vpm (Hz)	2400 (40)	
Gradeability with vibration	%	50	
Gradeability without vibration	%	55	

1.7 Lubrication

	Type	Quantity
Engine Crankcase	SAE 15W40, CD rated	2.5 qts (2.5 litres)
Hydraulic System	*SAE 10W30 - Hydraulic Fluid	10.5 gal. (40 litres)
Exciter	SAE 10W	32 oz. (.95 litres)
Drum Drive Gearcase	SAE 10 W	8 oz. (240 ml)
Articulated Joint	Shell Alvania No. 2	As required
Steering Cylinder	Shell Alvania No. 2	As required

* See Section 1.38 Hydraulic Oil Requirements.

1.8 Controls & Service Locations - Roller

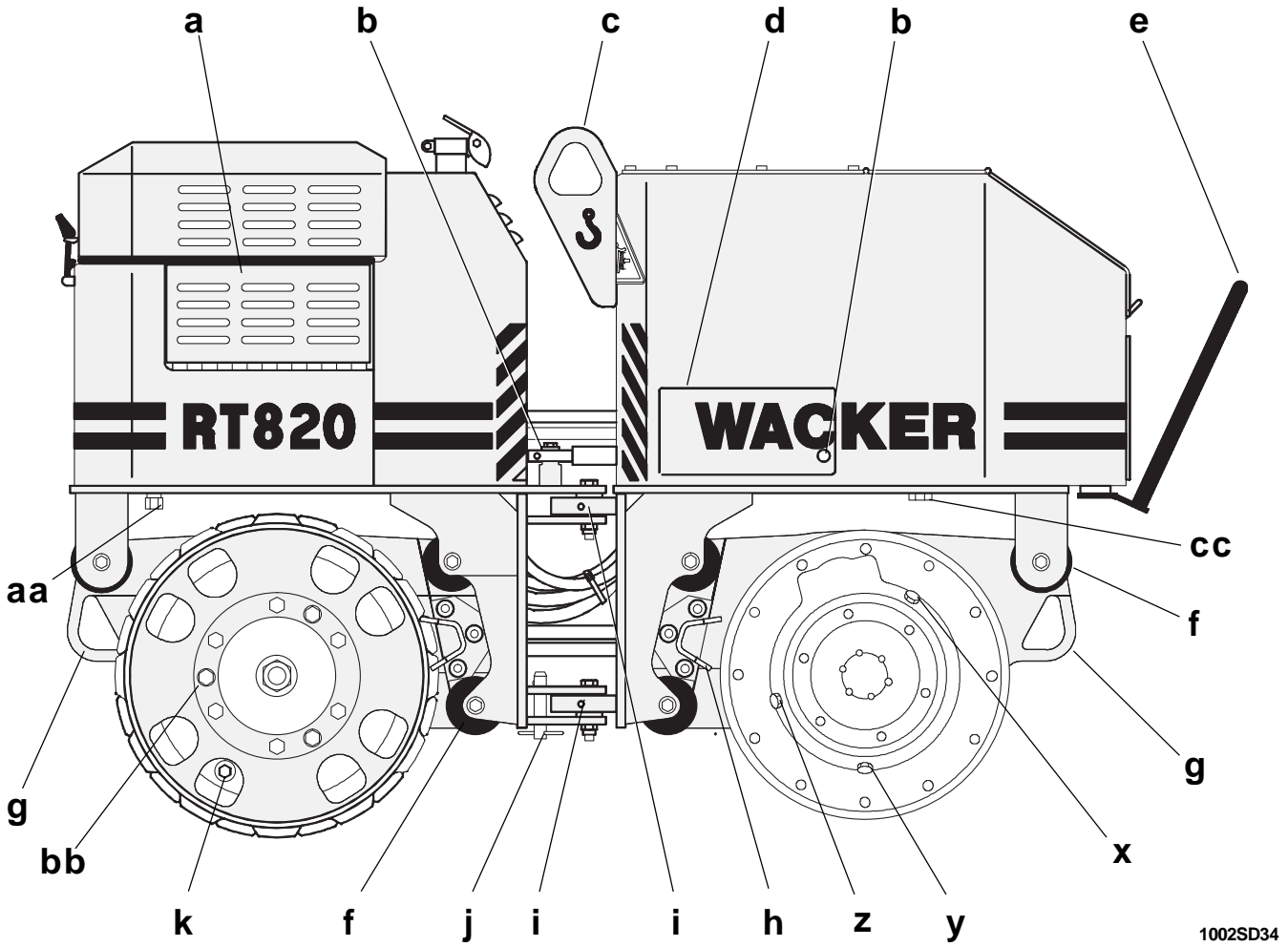

1002SD34

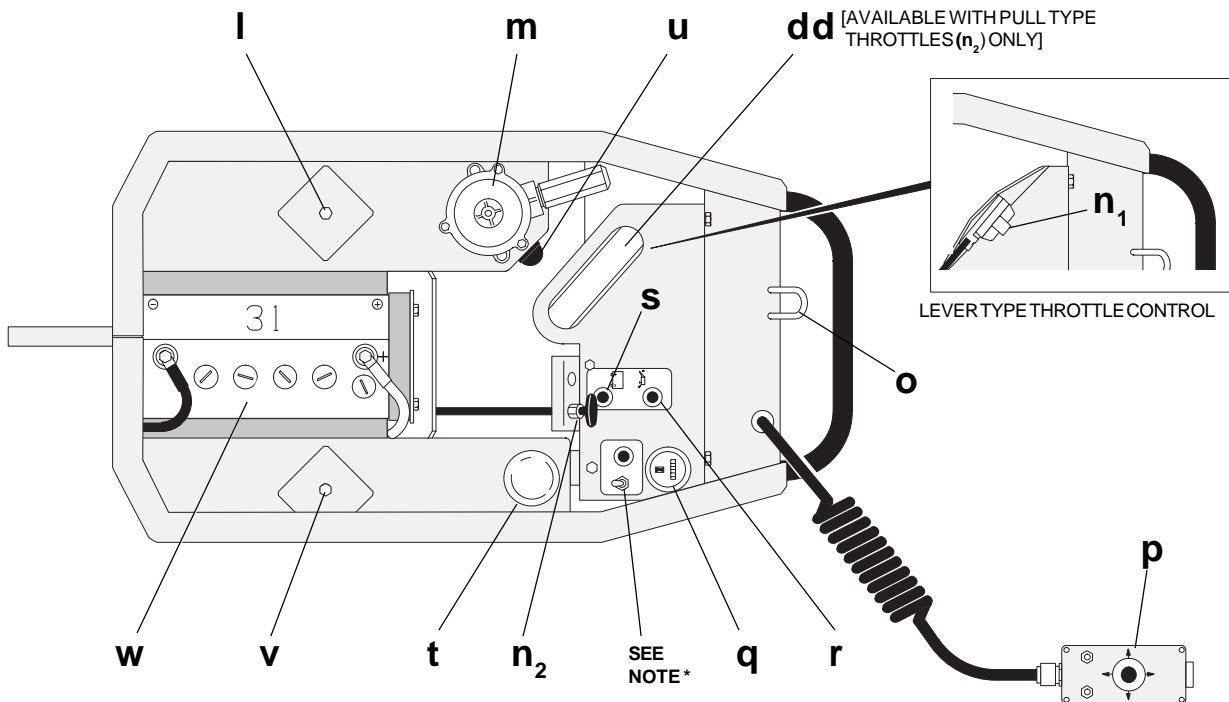

1006SD32

1.9 Service Locations - Engine

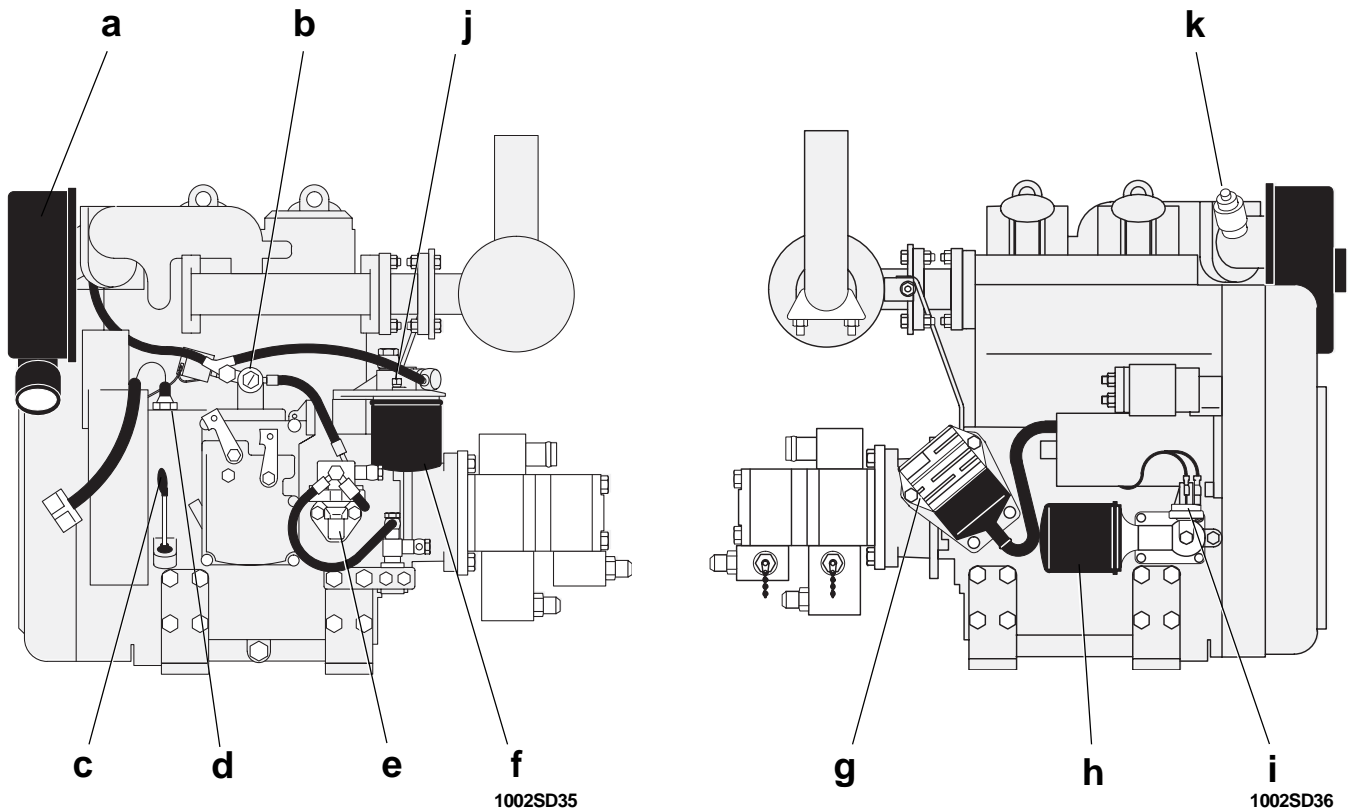

Roller

- | | |
|--|--|
| <ul style="list-style-type: none"> a Fuel Filter & Oil Dipstick Access Door
Oil Filter Access Door (opposite side) b Steering Cylinder Grease Fitting c Lifting Eye d Steering Cylinder Access Panel e Safety Bar f Shockmount g Tie Down Lug h Scraper Bar i Articulated Joint Grease Fitting j Articulated Joint Locking Pin k Exciter Oil Level Sight Plug l Hydraulic Tank Vent m Hydraulic Tank Return Line Filter n₁ Engine Throttle Control (Lever Type) n₂ Engine Throttle Control (Pull Type) | <ul style="list-style-type: none"> o Padlock Ring p Control Box q Hour Meter r Charging System Warning Light s Engine Oil Pressure Warning Light t Fuel Cap u Hydraulic Oil Level Sight Gauge v Fuel Tank Vent w Battery x Drive Case Fill Plug y Drive Case Drain Plug z Oil Level Plug aa Engine Oil Drain Plug bb Drum Pusher Holes cc Fuel Tank Drain Plug dd Control Box Storage Area |
|--|--|

Engine

- | | |
|---|---|
| <ul style="list-style-type: none"> a Air Cleaner b Fuel Line Bleed Screw c Oil Dipstick d Oil Pressure Switch (Warning Light) e Fuel Pump f Fuel Filter | <ul style="list-style-type: none"> g Voltage Regulator h Oil Filter i Oil Pressure Sending Unit (Engine Shut Down) j Fuel Filter Bleed Screw k Filter Indicator for Air Cleaner |
|---|---|

* **Note:** For machines equipped for infra-red remote control see "REMOTE CONTROL SYSTEM", starting on page 2-1.

1 OPERATION

1.10 Before Starting

Before starting machine check the following:

1. Engine oil level.
2. Condition of air cleaner.
3. Fuel level.
4. Hydraulic fluid level.
5. Position of locking pin at articulated joint.

1.11 Starting

1. Check that vibration switch **(a)** is set to "OFF".
2. Set throttle control between 1/2 - 3/4 open.
3. Turn ignition switch **(c)** on control box to "START" and crank starter until engine starts. Leave key switch in the "RUN" position while operating machine.

Note: On machines equipped with Infra-red remote control, set the Remote/Cord selector switch to "CORD CONTROL". The machine can now only be started using the control box. See "REMOTE CONTROL SYSTEM", page 2-5, for start up procedures using the infra-red transmitter.

CAUTION

DO NOT crank engine more than 15-20 seconds at a time or starter motor may overheat. Wait 30-45 seconds between start-up attempts so starter motor can cool down.

Note: The engine is equipped with a low oil shut down feature. If the engine does not start, check both the fuel and engine oil levels.

4. After engine starts, open throttle completely. Allow engine to warm up for a few minutes before operating machine.

1.12 Stopping

Make sure vibration is turned off. Turn ignition switch **(c)** to "OFF" to close fuel valve and stop engine.

Note: The engine cannot be shut down using the throttle lever. The throttle lever only returns the engine to idle.

1.13 Travel

Travel speed is controlled by a two position toggle switch **(b)** located on the control box.

There are two travel speeds available. High speed travel for movement around the jobsite and low speed travel for compaction.

Note: High speed travel is not available when operating the machine using the infra-red remote control system.

When operating in high speed the vibration function becomes inoperative.

Although vibration will automatically stop when switching to high speed, it is recommended that the vibration switch **(a)** be set to "OFF". This will prevent vibration from coming on unexpectedly when switching back to low speed.

1.14 Direction & Steering Control

The joystick **(d)** on the control box controls both direction and steering. When held as shown in the illustration below, the movement of the machine corresponds to the movement of the joystick.

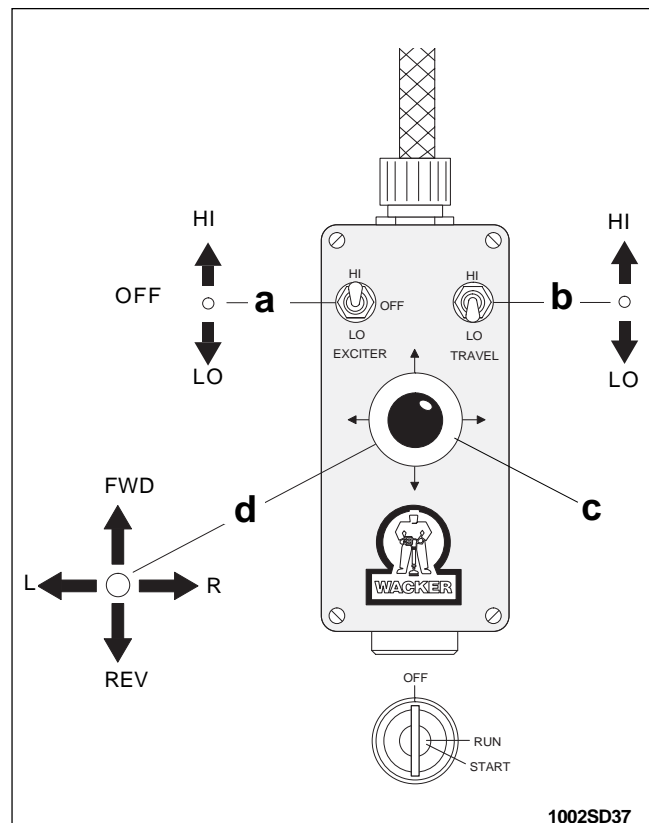

1.15 Vibration

There are two vibration modes available. Low amplitude vibration for loose soils with granular content such as gravel, and high amplitude vibration for cohesive type soils like clay.

Vibration is **only** available with the machine in the **low speed** travel mode.

Vibration is controlled by a three position switch located on the control box. To start vibration, set machine to low speed travel, then flip vibration switch to either high amplitude or low amplitude vibration.

Position switch in the off position to stop vibration.

Because the exciter weights must reverse direction when switching between vibration modes, there is a ten second delay built into the vibration circuit. This allows time for the weights to come to a complete stop.

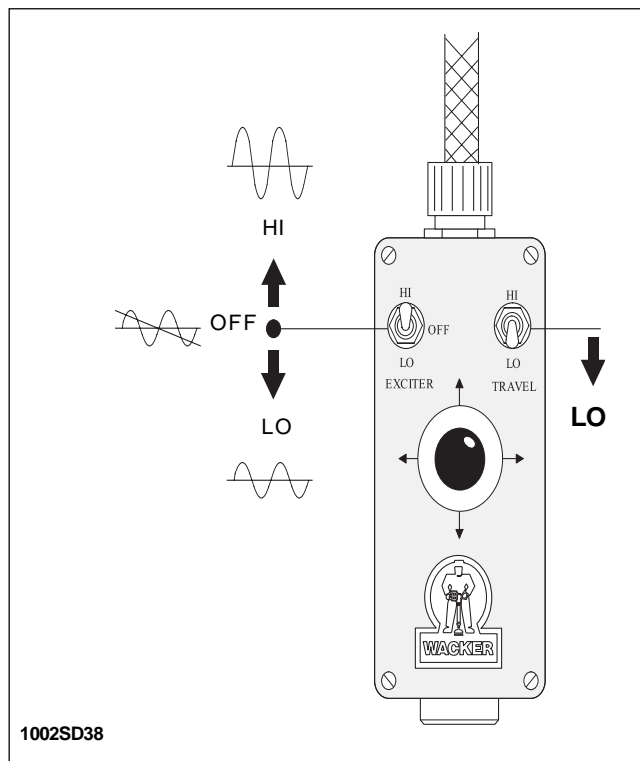

1.16 Safety Bar

A safety bar is mounted to the rear section of the machine behind the control panel.

If the machine backs into an obstruction or for some reason the operator becomes trapped behind it, the bar will be pressed forward and stop the machine. The machine will resume reverse travel when the bar is released.

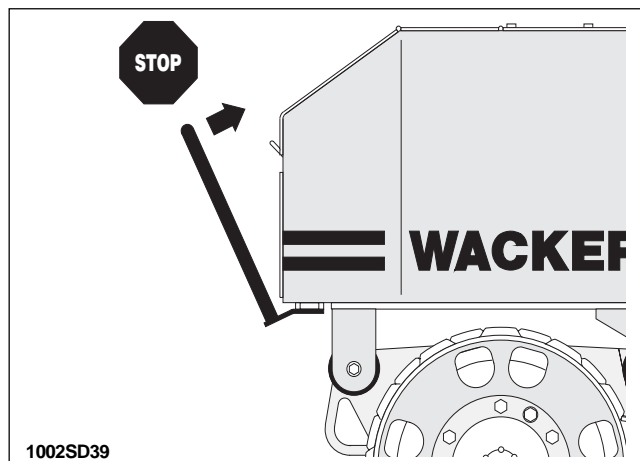

1.17 Operation on Slopes

When operating on slopes or hills special care must be taken to reduce the risk of personal injury or damage to the equipment. Whenever possible operate machine up and down hills rather than from side to side to improve stability and reduce the possibility of a roll over. We recommend that for safe operation restrict use to slopes of 14° (25% grade) or less.



WARNING

NEVER operate machine on side slopes greater than 26° (50% grade). At slopes greater than this the machine may roll over, even on stable ground.

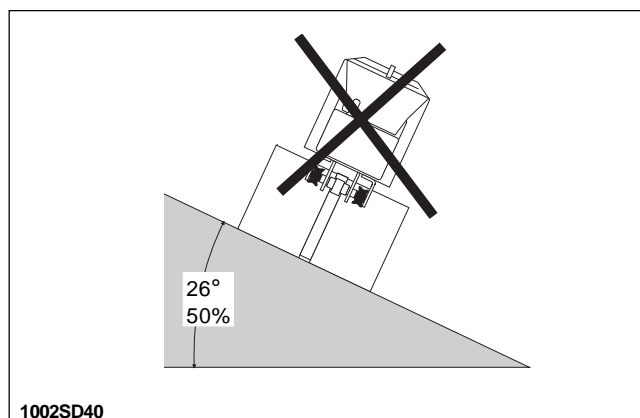

1.18 Engine Speed

During operation run engine at full throttle (2600 rpm). This ensures maximum exciter speed and will produce the best compaction.

1.19 Engine Oil Pressure Light

The oil pressure warning light (**s**) will come on when oil pressure falls to 7 psi (0.5 bar).

CAUTION

DO NOT continue to operate machine with warning light on or engine damage may occur. Stop engine and check oil level.

1.20 Charging System Light

The engine is equipped with an alternator and voltage regulator to maintain the battery charge. The charging system warning light (**r**) indicates the condition of the battery charging system. Although the machine will run with the light on for a short period of time, continued operation will drain the battery and eventually cause the machine to lose all operating functions.

CAUTION

If operating machine in a narrow trench or other confined area, drive machine into a safer area as soon as possible to avoid stranding it in a hazardous or inaccessible location.

1.21 Hour Meter

The hour meter (**q**) will run only with the ignition switch in the "on" position and the engine running.

1.22 Articulated Joint Locking Pin

A locking pin is provided to secure the front and rear halves of the machine together.

When lifting the machine secure the articulated joint with the locking pin as shown (**a**). When operating the machine store the locking pin in the storage hole (**b**).

1.23 Automatic Engine Shut-off

The engine will automatically shut down, if oil pressure falls below 4 psi (0.3 bar).

If the engine stops unexpectedly during operation, check engine oil level before resuming operation.

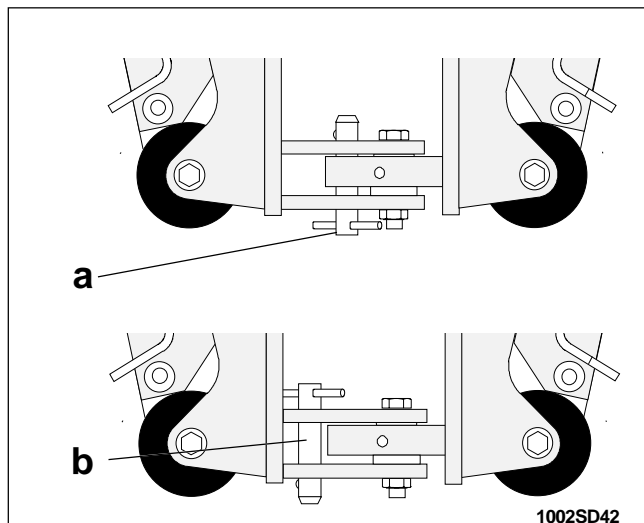
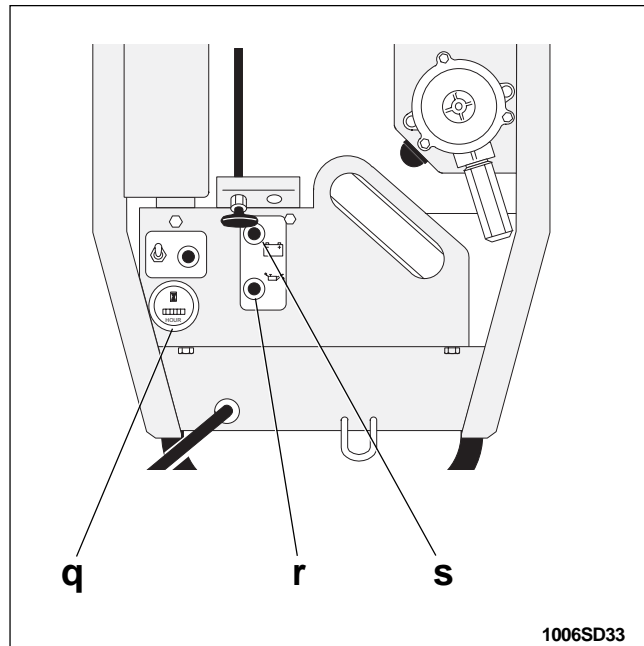

1.24 Engine Fuel Delivery System Maintenance

Maintenance to the engine fuel delivery system should be performed by an experienced mechanic familiar with diesel engines. For detailed maintenance procedures on the engine fuel system, refer to the engine manual, supplied with the machine at time of shipment.

1.25 New Machines

Perform the following after the first 50 hours of operation.

1. Change engine oil and replace oil filter after first 50 hours.
2. Replace hydraulic return line filter after first month or 100 hours.

1.26 Periodic Maintenance Schedule

	Daily Before Starting	Every 100 Hours	Every 300 Hours	Every 500 Hours	Every 1000 hours
Check engine oil. Fill to correct level.	●				
Check hydraulic oil. Fill to correct level.	●				
Check air filter. Replace as required.	●				
Grease articulated joint.		●			
Grease steering cylinder.		●			
Check battery fluid level.		●			
Clean engine head and cylinder fins.		●			
Change oil in engine crankcase.		●			
Replace engine oil filter.		●			
Replace fuel filter cartridge.			●		
Check valve clearance.			●		
Clean injectors and check injector pressure.			●		
Clean battery terminals				●	
Change oil in drive gear case.				●	
Change hydraulic system return line filter.					●
Change hydraulic fluid.					●
Change exciter oil.	Every two years				

1.27 Air Cleaner

Inspect air cleaner daily and replace as needed. On machines equipped with a filter indicator, replace filter element when red poppet in indicator pops up.

The air cleaner assembly consists of a mesh pre-cleaner, a dry type pleated paper element, o-ring and cover.

To inspect air cleaner:

Remove cover and inspect paper element. Replace paper element if it appears heavily soiled or engine has lost power. Line up tabs on cover with slots in housing and install cover. Be sure cover is seated tightly against o-ring. If o-ring is damaged it must be replaced. The pre-cleaner can be washed using either soap and water, or diesel fuel.

CAUTION

If the pre-cleaner is washed in diesel fuel, it must dry completely before installing it back in air cleaner or engine may race when started.

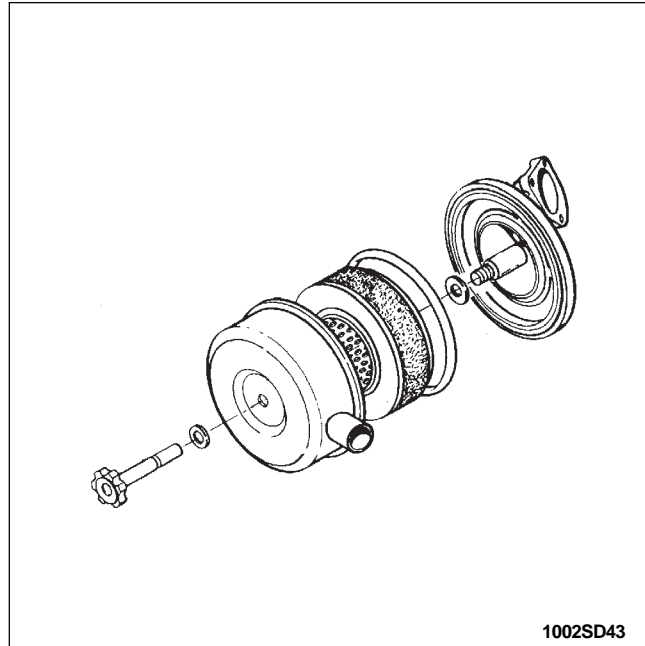

1.28 Engine Lubrication

Check engine oil level daily. Add oil as required. Change oil and oil filter every 100 hours. On new machines change oil after first 50 hours of operation.

To check oil:

Place machine on a level surface, remove dipstick and check that oil level is at top mark. Add oil through oil filler cap (a) on top of engine checking occasionally with dipstick. **DO NOT** overfill.

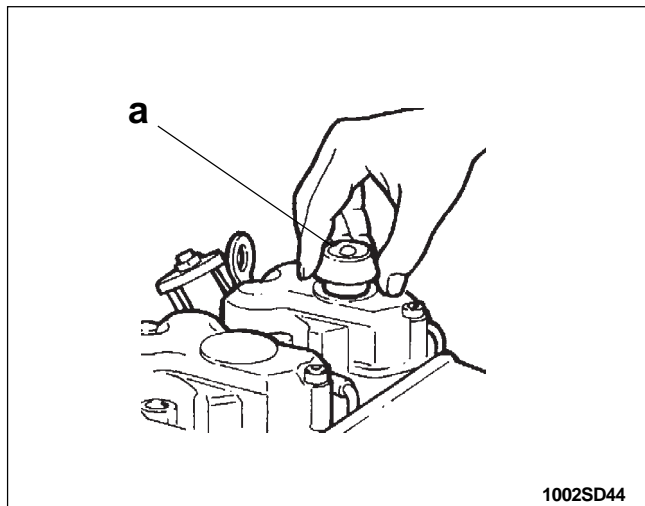

Use SAE 15W40 oil, rated CD.

Note: If oil level falls too low causing oil pressure to drop below preset value, engine will not start or may shut down during operation.

1.29 Articulated Joint & Steering Cylinder

Lubricate top and bottom bearing blocks (i) and cylinder knuckles (b) every 100 hours using a hand held grease gun.

Use Shell Alvania No. 2 or an equivalent No. 2 general purpose grease.

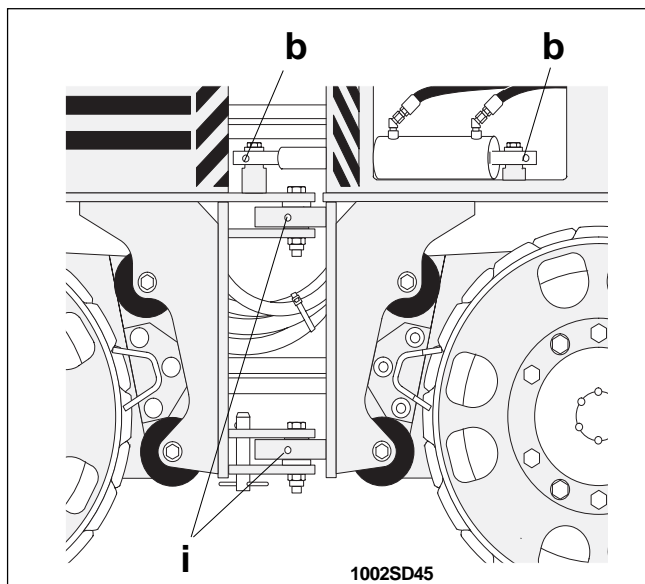

1.30 Drive Gearcase

Change the oil in the drive gearcase once a year or every 500 hours of operation.

To change oil:

1. Remove drum from drivecase side of machine. On the front drum this will be on the right side, on the rear drum it is the left side.
2. Open fill plug (x) for venting and then remove drain plug (y) from bottom of drum assembly.
3. Install drain plug and remove level plug (z) from gearcase.
4. Add SAE 10W oil through fill plug opening until oil flows out of level plug opening, approx. 8 oz. (240 ml).
5. Replace plugs and install drum.

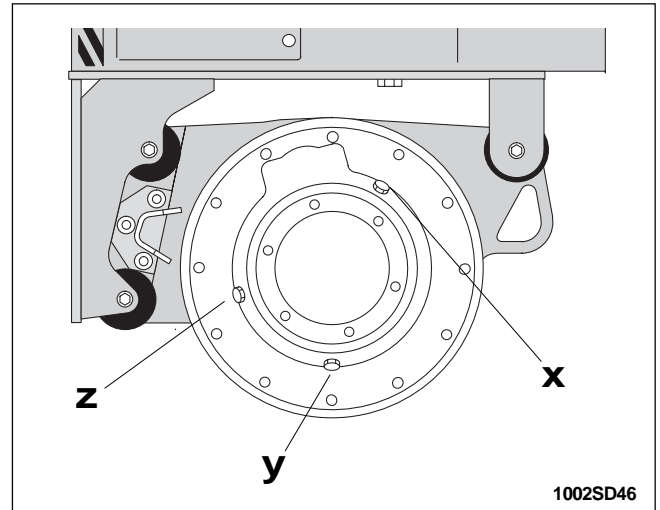

1.31 Exciter

The exciter is a sealed unit and under normal conditions should not require any periodic maintenance, however, an oil change once every two years is recommended to ensure bearing life.

Changing the exciter oil requires special tools and should be performed by an experienced mechanic. Please contact a WACKER Customer Support Center.

Note: Exciters on early production machines were equipped with a sightglass to check oil level. To view sightglass, remove plug (k) from drum cover.

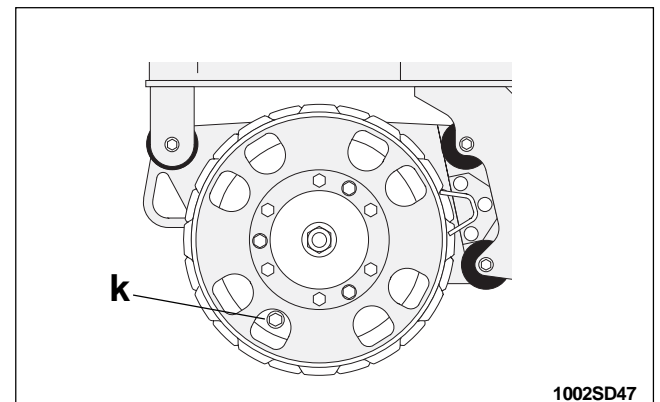

1.32 Engine Valve Clearance

Check and adjust valve clearance every 500 hours.

Remove rocker arm cover and check gaskets for breakage. Set clearance with engine cold. Bring each cylinder piston to top dead center on the compression stroke and set clearance.

Valve clearance .006 - .008 in. (0.15 - 0.20 mm).

Replace cover and tighten to 14 ft. lbs. (19 Nm).

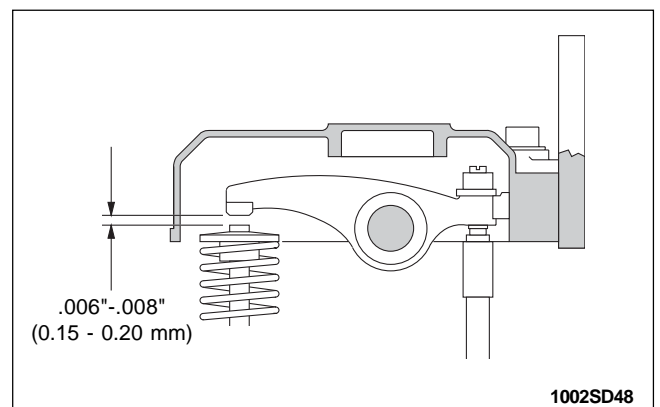

1.33 Fuel Filter

Change engine fuel filter every 300 hours of operation.

Drain fuel tank and remove filter(**f**) from engine block. Install new filter and bleed fuel lines.

1.34 Priming Fuel System

If the fuel tank has been run completely dry or drained for service it will be necessary to manually prime the fuel system.

To prime fuel system:

1. Install a jumper wire to connect both sides of oil pressure sending unit. (See page 1-7, Engine Section item i.) Turn ignition switch to "run". This will open fuel valves.
2. Loosen bleed screw (**j**) on fuel filter and pump lever on fuel pump (**e**) until fuel flows freely from bleed screw. Tighten bleed screw.
3. Repeat procedure for fuel line bleed screw (**b**).
4. Remove jumper wire and crank engine.

1.35 Cleaning Engine Cylinder Cooling Fins

The engine is air cooled and depends on the cylinder cooling fins to dissipate heat. In dusty conditions the cooling fins may become clogged or covered with dust reducing engine cooling.

Remove engine cover and inspect engine cooling fins every 100 hours.

Remove dirt build-up using a brush and diesel fuel or kerosene. Dry using compressed air. Replace inspection cover before starting engine.

1.36 Scraper Bars

Scraper bars are provided on both drums to prevent dirt from building up on the drum surfaces. These bars should be inspected and adjusted periodically as the drum wears.

To adjust scraper, loosen the three locknuts holding the bars to the drum casting. Position the bar as close to the drum as possible. Run machine and check that the scraper bar does not rub against the drum surface.

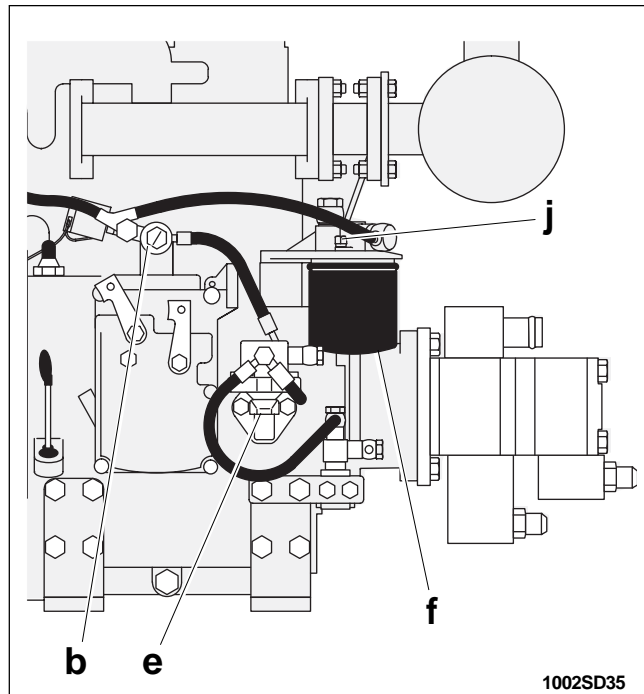

1.37 Shockmounts

Inspect the drum shockmounts every 300 hours for cracking, splitting or tearing. Replace shockmounts as needed.

CAUTION

The shockmounts isolate the upper part of the machine from the heavy vibrations produced in the drums. Operating the machine with damaged shockmounts for an extended period of time may eventually damage other machine parts.

1.38 Hydraulic Oil Requirements

WACKER recommends the use of a premium grade, petroleum based hydraulic oil with anti-wear and anti-foam characteristics. Good anti-wear oils contain zinc and molybdenum additives to reduce oxidation, prevent foaming, and provide for good water separation. These oils offer superior motor and pump life.

When selecting hydraulic fluid for your machine be sure to specify anti-wear properties. WACKER offers a premium grade hydraulic oil for use in this machine. In addition to its anti-wear properties, this oil has been colored to make it easier to view in the sight glass and spot hydraulic leaks.

WACKER Hydraulic Oil - P/N 85094

Avoid mixing different brands and grades of hydraulic fluids.

Oil Viscosity

Most hydraulic oils are available in different viscosities. The SAE number for an oil is used strictly to identify viscosity. It does not indicate the type of oil (engine, hydraulic, gear, etc.) The higher the SAE number, the thicker the oil.

For normal applications use a good non-detergent, anti-wear, hydraulic oil rated at SAE 10W30.

1.39 Changing Hydraulic Fluid & Filter

1. Remove drain plug from bottom of hydraulic tank and allow hydraulic fluid to drain.
2. Clean filter housing cover. Remove cover from the filter housing and remove the filter element **(m)**.

CAUTION

Be extremely careful to avoid dropping anything into the filter housing while cover is off.

3. Install drain plug.
4. Fill hydraulic tank through filter housing using clean hydraulic fluid.
5. Install new filter element and replace housing cover.

1.40 Hydraulic Fluid Level

A hydraulic oil level sight gauge is located on the hydraulic tank inside the rear section of the machine.

Check that the oil level is within one inch to the top of the sight gauge. Add oil as required through the filter housing on top of hydraulic tank.

If hydraulic oil continually needs to be added, inspect hoses and connections for possible leaks. Repair hydraulic leaks immediately to prevent damage to hydraulic components.

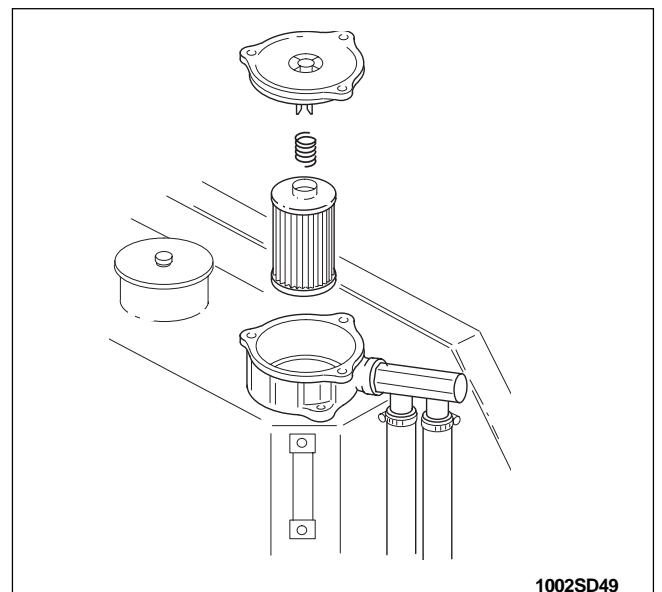

1 MAINTENANCE

1.41 Transporting Machine

When transporting the machine place blocks in front of and behind each drum and use the tie down lugs (**g**) provided to securely fasten the machine to the trailer.

1.42 Lifting Machine

Secure front and rear machine halves together using the locking pin (**j**) at the articulated joint. Place sling or chain through the central lifting eye (**c**) on the machine. Use a lifting device with sufficient weight bearing capacity.

ALWAYS lock the articulated joint before lifting the machine.

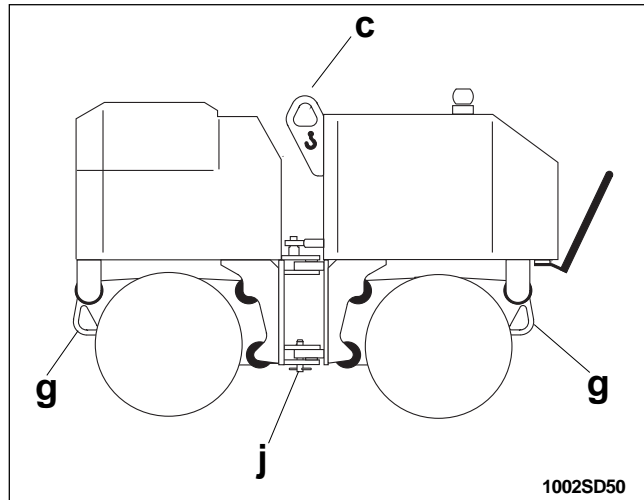

1.43 Changing Drums

The drums can be changed to adjust the working width of the machine. Drums are available in two sizes and provide a working width of either 32 in. (820 mm) or 22 in. (560 mm).

To change drum:

1. Lock the articulated joint.
2. Remove scraper bars.
3. Use a screw jack, hoist or other type of lifting device to lift drums one or two inches (25-50 mm) off the ground. Lift only one end of the machine. Keep the other end in contact with the ground for stability.
4. Use a 22mm wrench and remove the six screws which hold the drum to the drum support.
5. Remove the three plugs (**y**) covering the pusher holes.
6. Insert three of the mounting screws into the pusher holes and thread them in evenly to push drum off.
7. Install new drum and fasten to support. Secure mounting screws with a medium threadlocking adhesive.
8. Install the correct size scraper bars.

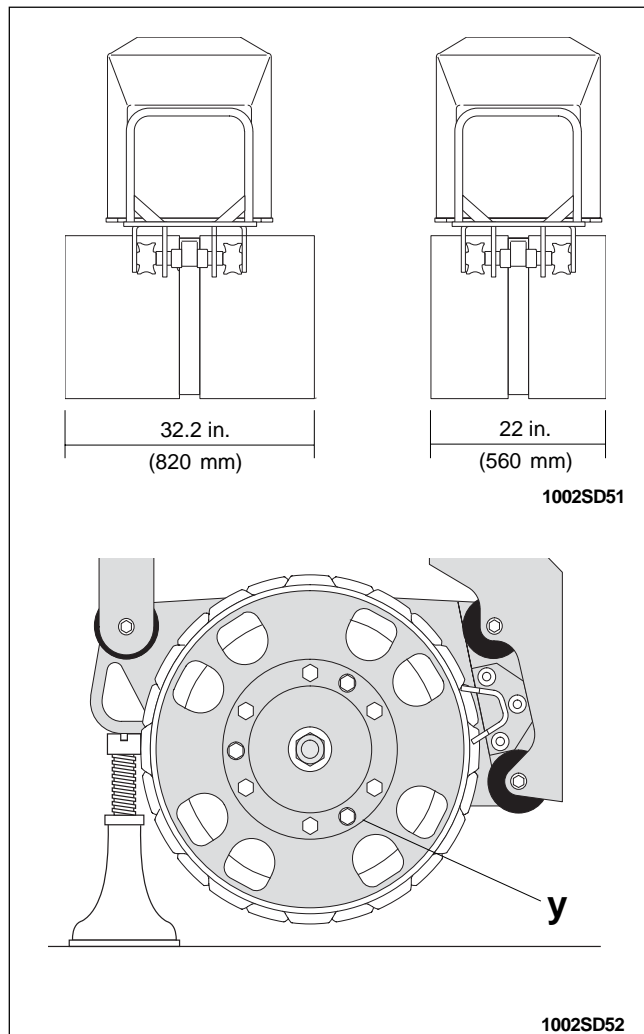

1.44 Battery

The battery supplied on this machine is a heavy duty lead acid cell, rated at 12V, 160 Ah, BCI group 31. Check level of electrolyte in battery periodically and add distilled water as required to keep it at correct level.

Keep battery terminals clean and tight.

In cold weather diesel engines must crank at a fairly high speed. Maintain your battery at full charge. When replacing the battery use one with the highest cold cranking amperage available to improve your cold weather starting capabilities.

1.45 Tightening Hardware

Check hardware periodically. If a bolt or nut is loose, secure it in place using the appropriate threadlocking compound called for in the Parts Section of this manual. These compounds are readily available at most auto parts stores or can be ordered from WACKER Corporation. For a complete list of recommended compounds refer to the Sealant Product List at the end of this manual.

1.46 Jobsite Storage

Never allow machine to sit overnight in a ditch, trench or other low lying area which might fill with water during a heavy rain.

If leaving machine on the jobsite, remember to remove the key and lock the control panel cover and engine hood to prevent tampering. Both the control panel and engine hood are equipped with a locking ring (**w**) for use with a padlock for this purpose.

1.47 Long Term Storage

If storing unit longer than 30 days the following steps are recommended.

1. Change engine oil.
2. Clean or change air cleaner elements.
3. Clean engine cylinder cooling fins.
4. Drain and clean fuel tank. Replace fuel filter. Refill tank with fresh No. 2 diesel fuel.

Note: Diesel fuel is subject to bacterial growth which can contaminate fuel lines. Allowing the tank to sit dry for a long period of time helps promote such growth. The addition of a biocide to the fuel is recommended to inhibit bacterial growth and protect the engine fuel system.

5. Remove battery from machine and store it in a clean dry area. Charge battery once a month to maintain condition of electrolyte.
6. Store unit indoors in a clean dry area. If unit must be stored outside, cover it.

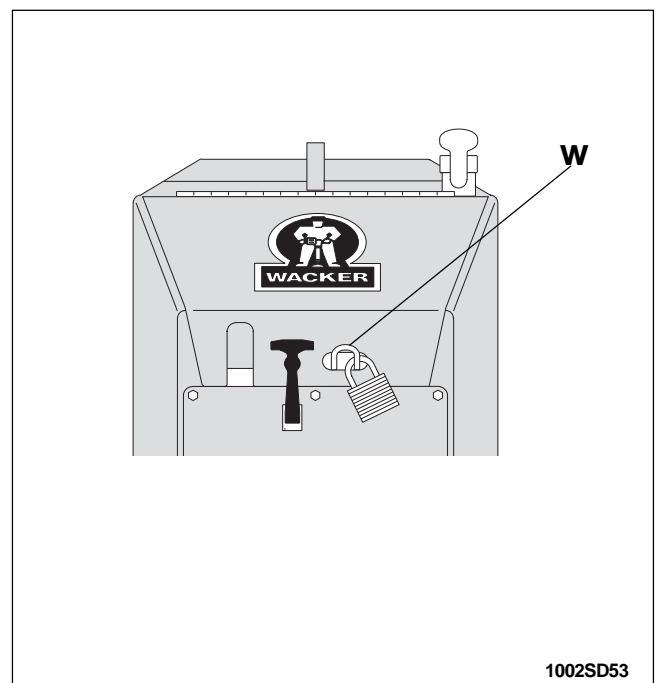

1.48 General

<p>ENGINE DOES NOT START</p>	<ol style="list-style-type: none"> 1. Fuel tank empty. Fill with No. 2 diesel fuel and prime fuel lines. 2. Wrong type of fuel. 3. Old fuel. Drain tank, change fuel filter and fill with fresh fuel. 4. Fuel system not primed. 5. Fuel filter restricted or plugged. Replace filter. 6. Battery connections loose or corroded. Battery dead. Electrolyte low. 7. Engine oil level low. 8. Air cleaner element dirty. 9. Starter motor defective. 10. Main fuse on engine wiring harness open. 11. Fuse on terminal block open. Replace fuse. 12. Ignition switch on control box defective. 13. Fuel valve solenoids on engine inoperative. 14. Starter relay inoperative. 15. Electrical connections loose or broken.
<p>ENGINE STOPS BY ITSELF</p>	<ol style="list-style-type: none"> 1. Fuel tank empty. 2. Fuel filter plugged. 3. Fuel lines broken or loose. 4. Oil pressure low. 5. Oil filter plugged.
<p>NO VIBRATION</p>	<ol style="list-style-type: none"> 1. Machine not in low speed travel mode. 2. Fuse on relay panel open. 3. Toggle switch on control box defective. 4. Solenoid on vibration valve inoperative 5. Vibration relay inoperative. 6. Vibration interlock defective. 7. Exciter assembly damaged. 8. Leak in hydraulic lines. 9. Exciter motor worn or damaged. 10. Exciter pump worn or damaged.
<p>NO TRAVEL or TRAVEL ONLY IN ONE DIRECTION</p>	<ol style="list-style-type: none"> 1. Joystick defective. 2. Toggle switch on control box defective. 3. Solenoid on travel valve inoperative. 4. Safety bar switch closed or defective. 5. Drive gearcase assembly damaged. 6. Leak in hydraulic lines. 7. Drive motor worn or damaged. 8. Drive pump worn or damaged.
<p>NO HIGH SPEED TRAVEL</p>	<ol style="list-style-type: none"> 1. Toggle switch on control box defective. 2. Solenoid on manifold inoperative. 3. Exciter pump worn or damaged.
<p>NOSTEERING</p>	<ol style="list-style-type: none"> 1. Joystick defective. 2. Solenoid on steering valve inoperative.

1.49 Hydraulic Schematic

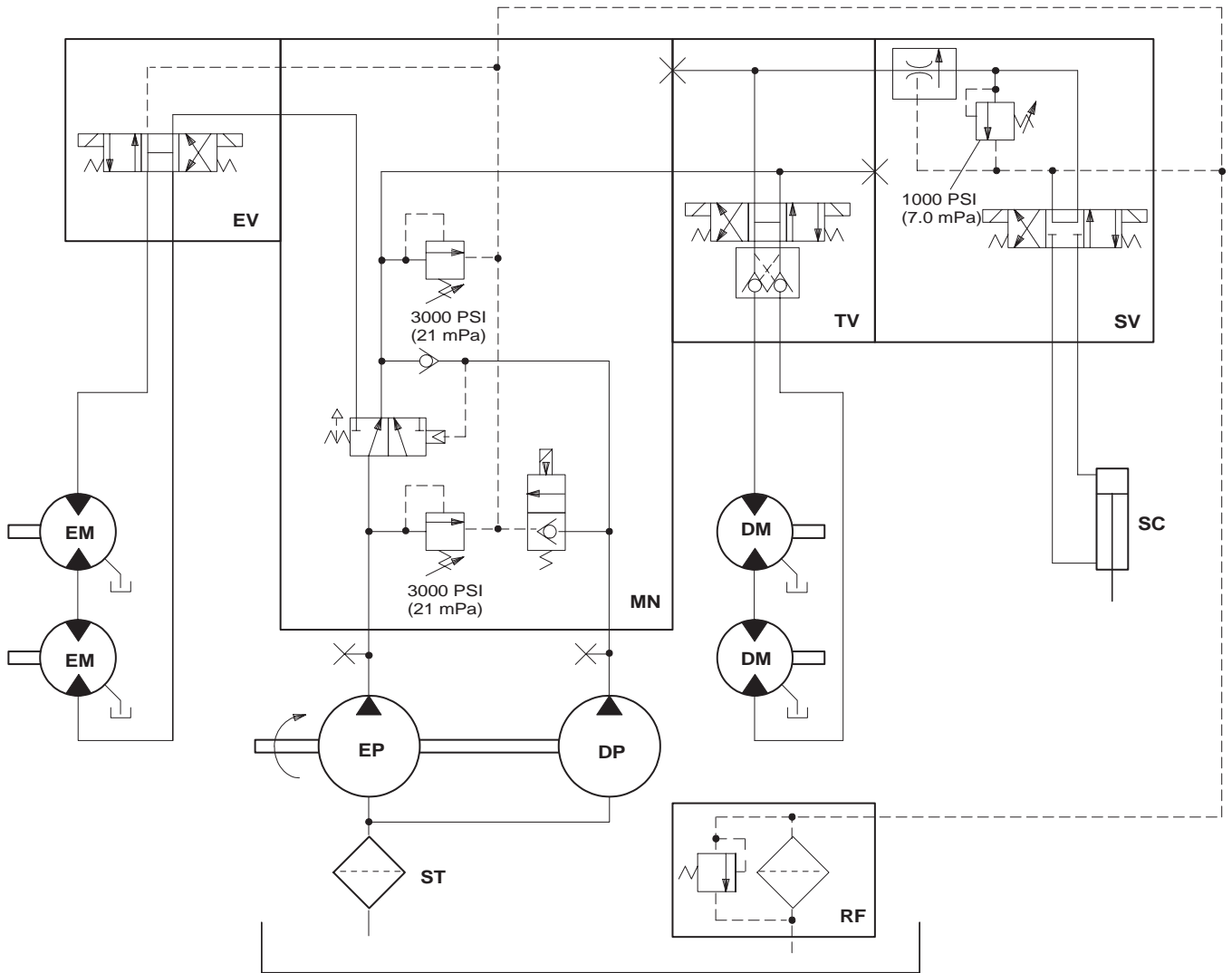

1002SD54

- DM** Drive Motor
- DP** Drive Pump
- EM** Exciter Motor
- EP** Exciter Pump
- EV** Exciter (Vibration) Valve
- MN** Manifold
- RF** Return Filter
- SC** Steering Cylinder
- SV** Steering Valve
- ST** Strainer
- TV** Travel Valve

1.50 Control Box Wiring Schematic

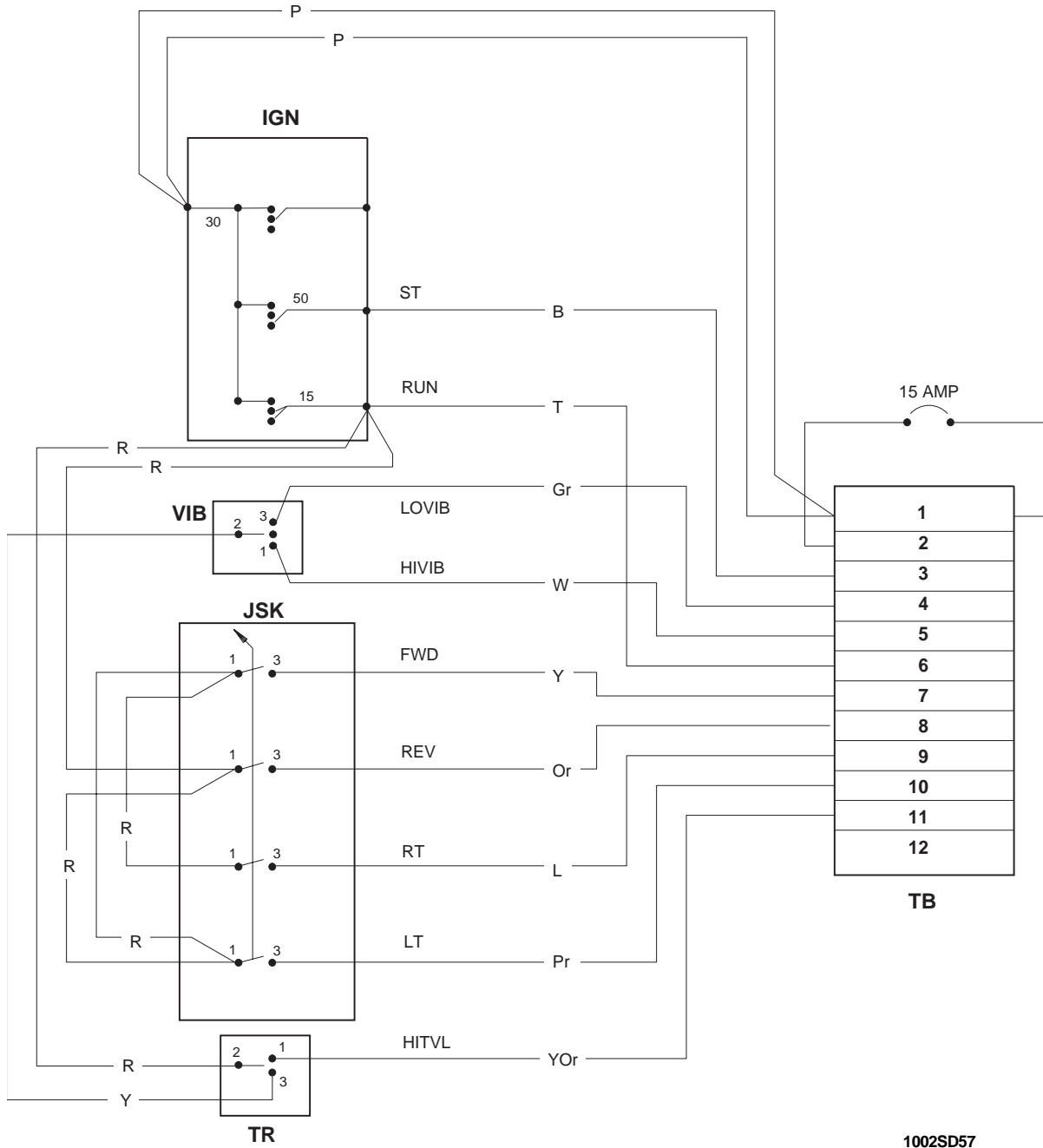

1002SD57

IGN Ignition Switch
JSK Joystick
TB Terminal Block
VIB Vibration Switch
TR Travel Switch

Wire Colors	
B - Black	W- White
G - Green	Y - Yellow
L - Blue	Br - Brown
P - Pink	Gr - Gray
R - Red	Or - Orange
T - Tan	Pr - Purple

1.51 Panel and Engine Wiring Schematic (W/15 Amp Vibration Relay Fuse)

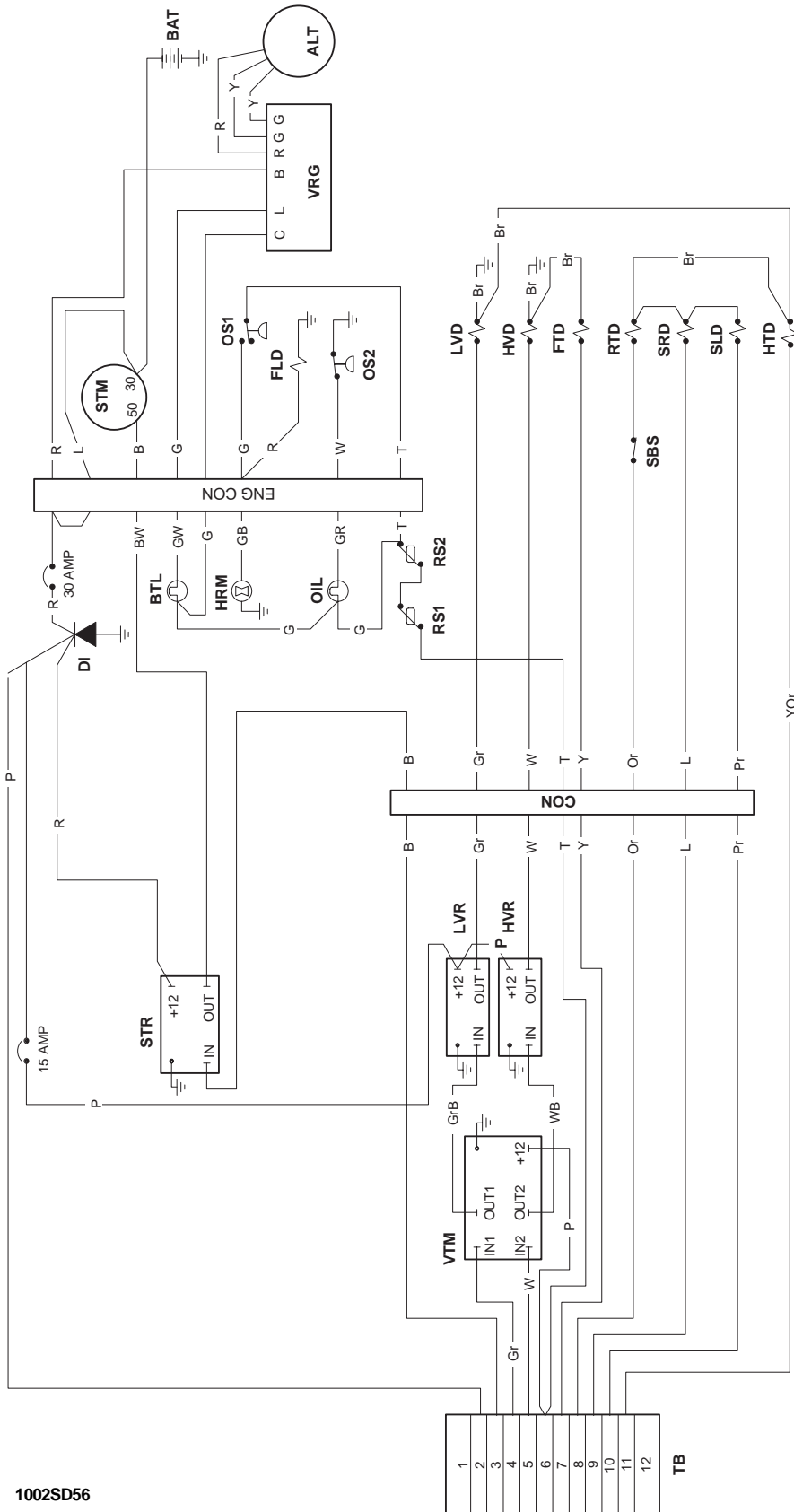

1002SD56

ALT	Alternator	HVD	High Vibration Solenoid	RS2	Rollover Switch (Right)
BAT	Battery (12V)	HVR	High Vibration Relay	RTD	Reverse Travel Solenoid
BTL	Battery Warning Light	LVD	Low Vibration Solenoid	SBS	Safety Bar Switch
DI	Diode	LVR	Low Vibration Relay	SLD	Steer Left Solenoid
FLD	Fuel Valve Solenoid	OIL	Oil Pressure Warning Light	SRD	Steer Right Solenoid
FTD	Forward Travel Solenoid	OS1	Oil Pressure Switch (4 psi)	STM	Starter Motor
HRM	Hour Meter	OS2	Oil Pressure Switch (7 psi)	STR	Starter Relay
HTD	High Speed Travel Solenoid	RS1	Rollover Switch (Left)	VTM	Vibration Timer

1.52 Panel and Engine Wiring Schematic (W/O 15 Amp Vibration Relay Fuse)

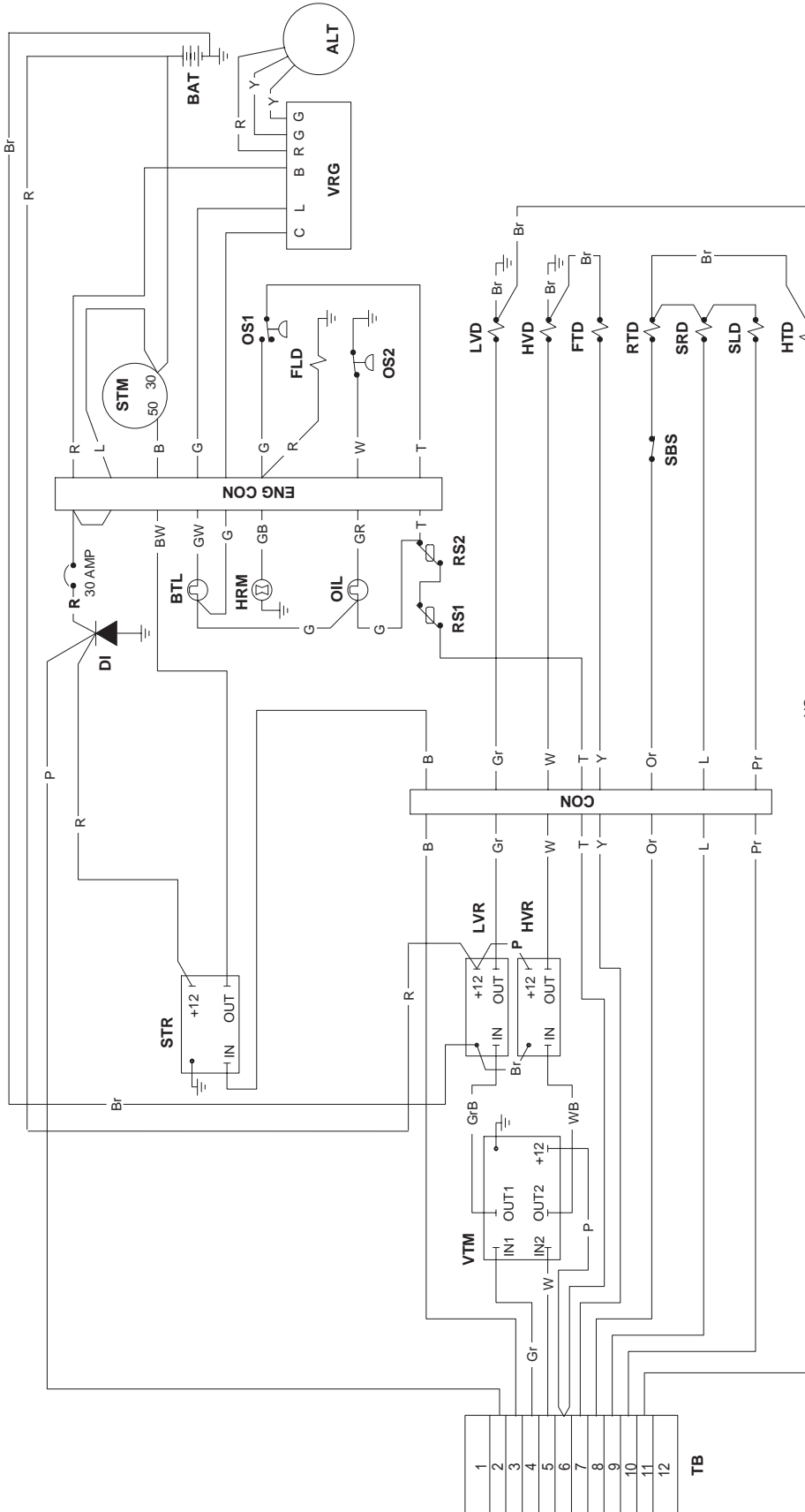

ALT	Alternator	HVD	High Vibration Solenoid	RS2	Rollover Switch (Right)
BAT	Battery (12V)	HVR	High Vibration Relay	RTD	Reverse Travel Solenoid
BTL	Battery Warning Light	LVD	Low Vibration Solenoid	SBS	Safety Bar Switch
DI	Diode	LVR	Low Vibration Relay	SLD	Steer Left Solenoid
FLD	Fuel Valve Solenoid	OIL	Oil Pressure Warning Light	SRD	Steer Right Solenoid
FTD	Forward Travel Solenoid	OS1	Oil Pressure Switch (4 psi)	STM	Starter Motor
HRM	Hour Meter	OS2	Oil Pressure Switch (7 psi)	STR	Starter Relay
HTD	High Speed Travel Solenoid	RS1	Rollover Switch (Left)	VTM	Vibration Timer

1002SD58

Table of Contents

	Page
2.1	Features 2-3
2.2	Transmitter Controls 2-4
2.3	Remote Control Selector Switch 2-5
2.4	Starting & Operation 2-5
2.5	Stopping Engine and Shutting Off Remote Control 2-5
2.6	Operating Range 2-5
2.7	High Speed Travel 2-5
2.8	Position of Operator 2-6
2.9	Operating Characteristics 2-6
2.10	Ni-cad Batteries 2-6
2.11	Charging Transmitter Batteries 2-6
2.12	Setting Channel (Tuning Transmitter) 2-7
2.13	Changing Channels 2-7
2.14	Maintenance 2-8
2.15	Cleaning Transmitter 2-8
2.16	Pressure Washing Machine 2-8
2.17	Replacing Transmitter Batteries 2-8
2.18	Troubleshooting 2-9
2.19	Relays and Engine Wiring Schematic 2-10 (W/ 15 Amp Vibration Relay Fuse)
2.20	Transmitter Wiring Schematic 2-11
2.21	Relays and Engine Wiring Schematic 2-12 (W/O 15 Amp Vibration Relay Fuse)

This section covers the operation and maintenance of the optional Infra-Red remote control system. The infra-red system provides wireless operation of the machine at distances up to 100 ft. (30 m). If your machine is equipped with this system please read and follow the instructions included in this section before operating the machine.

Since this system allows the operator to safely operate the machine from a distance it is important that visual contact with the machine be maintained at all times. Inattentive operation, while not necessarily dangerous to the operator, can be hazardous to other personnel and equipment on the jobsite.

2 REMOTE CONTROL

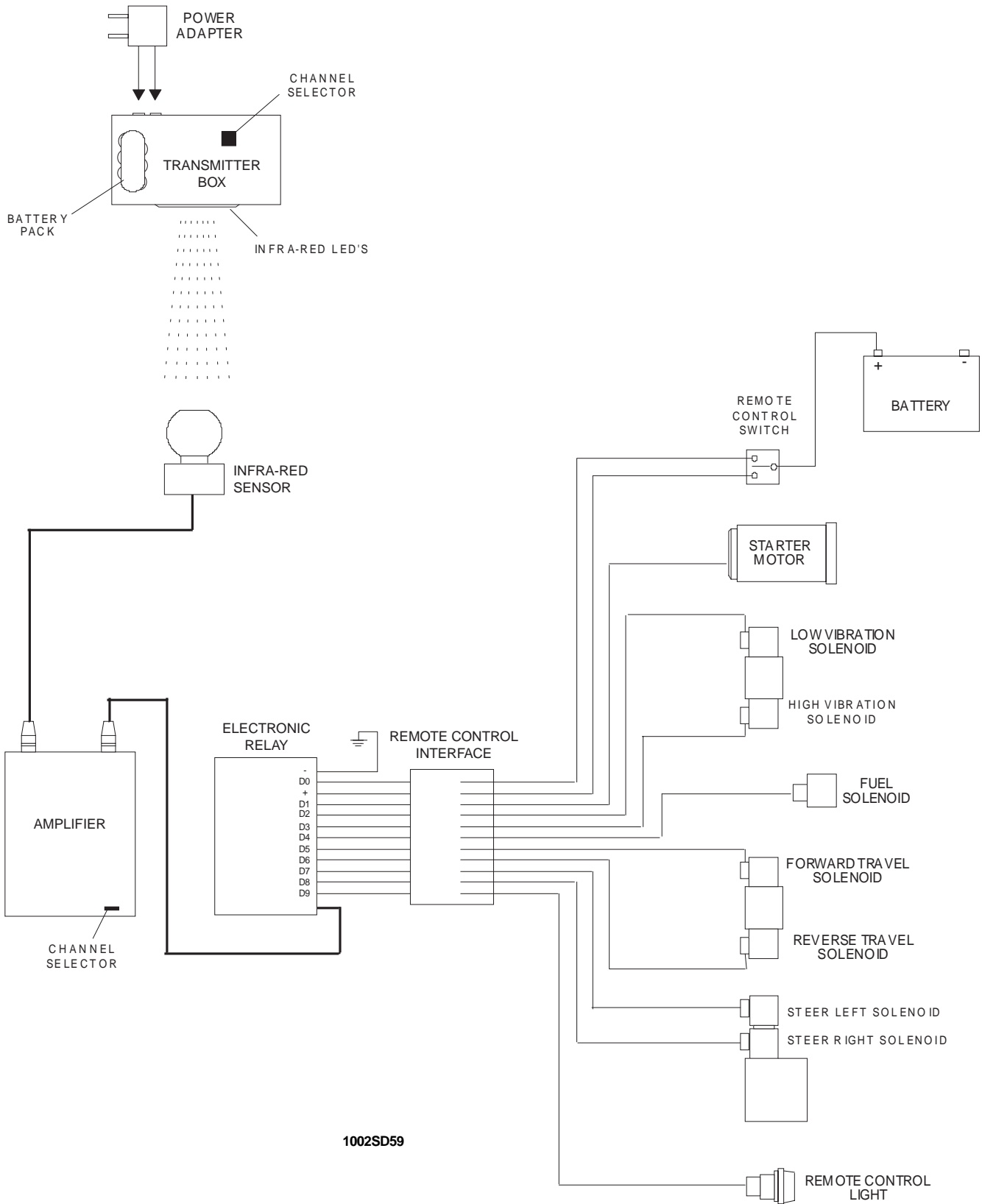

1002SD59

2.1 Features

The remote control system consists of:

1. Power Adapter
2. Transmitter
3. Infra-red (IR) Sensor
4. Receiver/Amplifier
5. Electronic relay
6. Remote Control Interface

Power Adapter

Used to recharge battery pack in transmitter.

- Plugs into standard 110-120V wall socket.
- Short protected connectors.
- Rating, 14-18 VAC, 500 mA

Transmitter

Receives the signals from the joystick and switches and transmits a coded infra-red transmission.

- Line of sight operation.
- 8 functions to control machine operations.
- 16 channel selection switch to allow operation of two or more machines without interference.
- 3 high power infra-red transmitting diodes.
- Charging circuit protection.
- Clear transmissions into direct sunlight, up to 100,000 LUX.
- Range - 100 ft. (30 m)
- Transmitting time - 6-8 hours
- Recharge time - 12-14 hours.
- Batteries - Six rechargeable Ni-cad batteries 1300 mAh capacity
- Power supply - 7.2 VDC

Infra-red Sensor

Receives, focuses, filters and amplifies transmission.

- 4 receiving diodes for full 360° receiving window.
- Integrated pre-amp.
- IR correction to filter outside light interference.
- Focusing lens body to strengthen signal input.
- Range - 38-46 kHz
- Enclosed in protective bracket.

Receiver/Amplifier

Receives coded transmission from sensor, decodes signal, amplifies and transmits information to electronic relay.

- Scans transmission 60 times a second, providing immediate response to changes in operating commands.
- Fully encapsulated circuitry, protected from dirt, moisture and vibration.
- 16 channel selection switch enclosed under protective cover.

Electronic Relay

Receives and responds to decoded signal from receiver to drive machine solenoids.

- Solid state design, no mechanical relays or switching.
- Fully encapsulated electronics, protected from dirt, moisture and vibrations.
- Double grounded for added circuit protection.
- Protected against shorts, overloads and current feedback.
- Automatic reset, fully electronic circuit protection up to 30 amps (50 amps for starting circuit)

Remote Control Interface

Directs power to solenoids from either cord controls or Infra-red remote controls.

- Full solid state circuitry, no mechanical switching.
- Protected from dirt, moisture and vibrations.

2.2 Transmitter Controls

a. Ignition Switch

The transmitter box is equipped with a three position ignition switch (OFF-ON-START) to activate the transmitter and operate the engine starter.

When switched to the "ON" position the transmitter is activated. The transmitter will remain active only as long as the switch remains in the "ON" position. When turned to "OFF" all transmitting functions cease and the fuel valve on the engine closes to stop the engine.

b. Joystick

The joystick controls the travel and steering functions. Four mechanical switches react to movements on the joystick and convert them to electronic signals which are then transmitted to the solenoids on the machine to open and close the hydraulic valves.

c. Vibration Switch

The three position rotary switch located at the bottom left on the transmitter box controls machine vibration.

- 0 - No vibration
- 1 - Low Amplitude Vibration
- 2 - High Amplitude Vibration

d. Red LED (Battery Charge)

The red LED shows the capacity of the batteries in the transmitter box. When battery capacity falls to 20% of its nominal rating it will begin to blink, indicating that the batteries need recharging. Transmission distance may begin to diminish.

If the battery charge falls to 10% or less, the red LED changes from a blinking light to a continuous light. Transmission is shut off. This avoids possible malfunctions caused by weak signals.

The red LED will come on momentarily when the start switch is first turned on or off.

e. Green LED

The green LED shows that the transmitter is operating and will start blinking rapidly when the ignition switch on the transmitter is turned to the "ON" position. It will

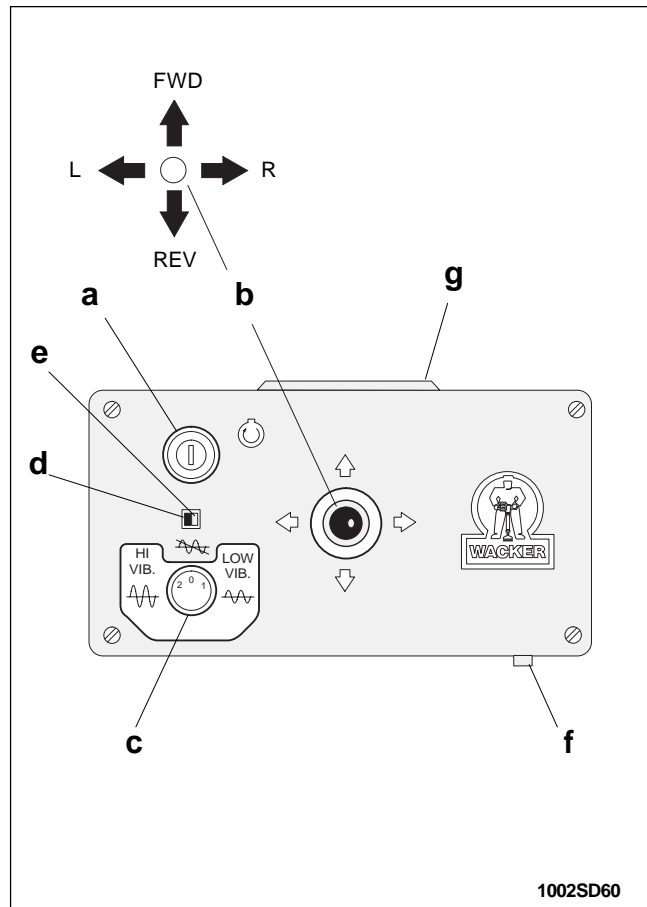

continue to blink until the ignition switch is turned off and transmission stops, or battery capacity falls below 10%.

f. Charging Jacks

Two jacks are provided on the back of the transmitter box allowing the batteries to be recharged without removing them from the transmitter.

g. Infra-red Emitting Diodes

Three diodes are used to transmit the coded infra-red signal to the receiving eye on the machine. Keep the red filtering window in front of the diodes clean to ensure maximum signal strength.

2.3 Remote Control Selector Switch

The Remote Control Selector Switch **(h)** sets the operating mode of the machine.

When the machine is not in use, the switch should be in the “CORD CONTROL” position. In this position the on board electronics for the remote control system are disabled and only cord operation is possible.

In the “REMOTE CONTROL” position the remote control system on the machine becomes active and will respond **ONLY** to signals from the transmitter.

An indicator light **(i)** will blink when the selector switch on the machine is switched to "REMOTE CONTROL". The light will continue to blink until the selector switch is returned to “CORD CONTROL”.

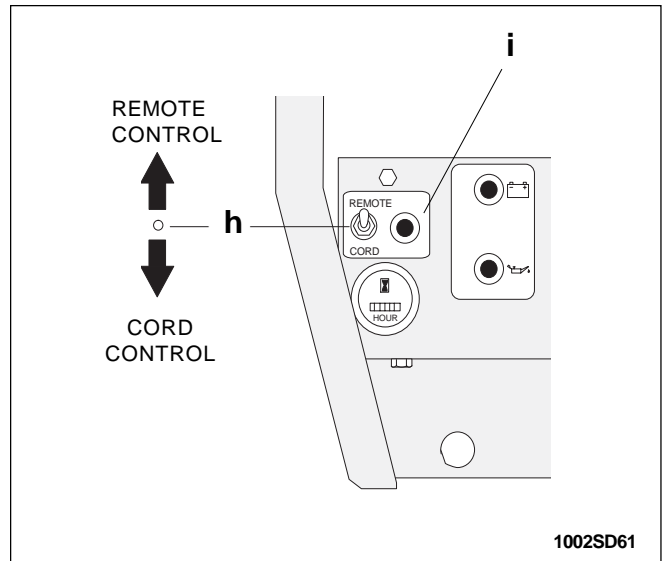

2.4 Starting & Operation

1. Set the selector switch **(h)** on the machine to “Remote Control”.
2. Open the engine throttle control on the machine to full speed.
3. Activate the transmitter by turning the ignition switch to “ON”. The green LED **(e)** on the transmitter will start to blink showing that the transmitter is operational.

Note: If the red LED on the transmitter comes on or blinks, the transmitter batteries are low and should be recharged. The machine can still be operated by turning the transmitter off and switching to cord control.

4. Aim the transmitter in the direction of the sensing eye on the machine.
5. Start engine using ignition switch **(a)**. Crank engine long enough to allow oil pressure to build up. Oil pressure must reach 4 psi before fuel valve opens.
6. Leave the key in the transmitter set to “ON” while operating under remote control.

Keep the transmitter pointed at the receiving eye on the machine at all times to maintain contact. If the transmitter is aimed away from the machine the fuel valve will close and shut down the engine.

2.5 Stopping Engine and Shutting Off Remote Control

1. Turn ignition switch on transmitter to “OFF”. The blinking green LED will go off and the fuel valve on the engine will close. The machine will continue running for 5-10 seconds until the fuel remaining in the fuel line is used up.
2. Set the selector switch on the machine to “CORD CONTROL”. The blinking red light will go out, indicating that the remote control system is off.

Note: If the remote control selector switch is not returned to "CORD CONTROL" the remote control system on the machine remains active and will drain the battery on the machine.

2.6 Operating Range

The transmitter will remain in contact with the machine at distances up to 100 feet (30m), although at this distance the transmitter must be aimed more precisely at the receiving eye on the machine. If operating into direct sunlight or with a low battery charge the operating range will decrease.

2.7 High Speed Travel

High speed travel is only available while operating under cord control.

2.8 Position of Operator

Although the sensing eye on the machine can receive signals from any direction, the joystick controller on the transmitter is wired so that its movements correspond to the movements of the machine with the operator standing **BEHIND** the machine.

For instance, when standing behind the machine **(a)**, pushing forward on the joystick causes the machine to move forward (away from the operator), pushing left would result in the machine turning left, etc. If the operator; however, stands in front of the machine **(b)** it will respond in a direction opposite to that of the joystick. Pushing forward on the joystick causes the machine to move toward the operator, pushing left results in the machine turning to the operator's right.

It is recommended that the operator follow behind the machine to avoid confusion. If the operator must change positions, it is important that he understand the changes that will occur in the control of the machine.

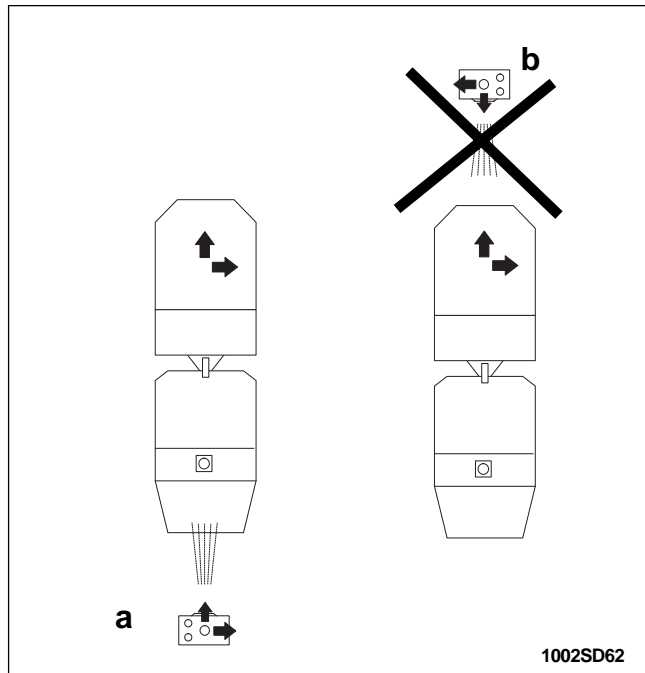

2.9 Operating Characteristics

In an enclosed area (such as a shop floor or warehouse) or an area surrounded by large structures, the infra-red signal may reflect off surrounding surfaces, causing it to be picked up by the machine even when the transmitter is pointed away from the machine. This condition is more pronounced at shorter distances when the signal strength is strong.

As the distance between the transmitter and machine increases, the intensity of the signal diminishes. This means that at greater distances the transmitter must be aimed more directly at the machine to maintain maximum signal reception.

In some instances, especially at greater distances, objects passing between the machine and transmitter (such as support beams) will block the signal. When this occurs the fuel valve will close and the engine will shut down, unless the signal can be re-established within 5-10 seconds.

2.10 Ni-cad Batteries

The batteries used to power the transmitter are high capacity Ni-Cad cells rated at 1300 mAh and are capable of accepting hundreds of charging cycles. If the machine fails to operate for the full operating period, even after batteries have been charging overnight, batteries may need to be replaced.

2.11 Charging Transmitter Batteries

The battery pack in the transmitter has enough capacity to provide 6-8 hours of continuous operation. To maintain battery capacity, charge batteries overnight at the end of each working day.

To charge batteries, plug power adapter into a standard 120V outlet and insert connectors into jacks provided on back of transmitter.

Approximately 12 -14 hours are required to bring the battery up to full charge. The transmitter will operate on a partial charge; however, its operating time will be reduced accordingly. For example, charging the batteries for 6 hours would provide approximately 4 hours of operation.

The charging circuit in the transmitter is self-regulating and limits the charging current from the power adapter to 100mA.

Use the power adapter provided with the machine.

CAUTION

DO NOT use a quick charger to charge the batteries inside the transmitter. These devices typically generate high currents and produce heat, which may damage the electronics inside the transmitter.

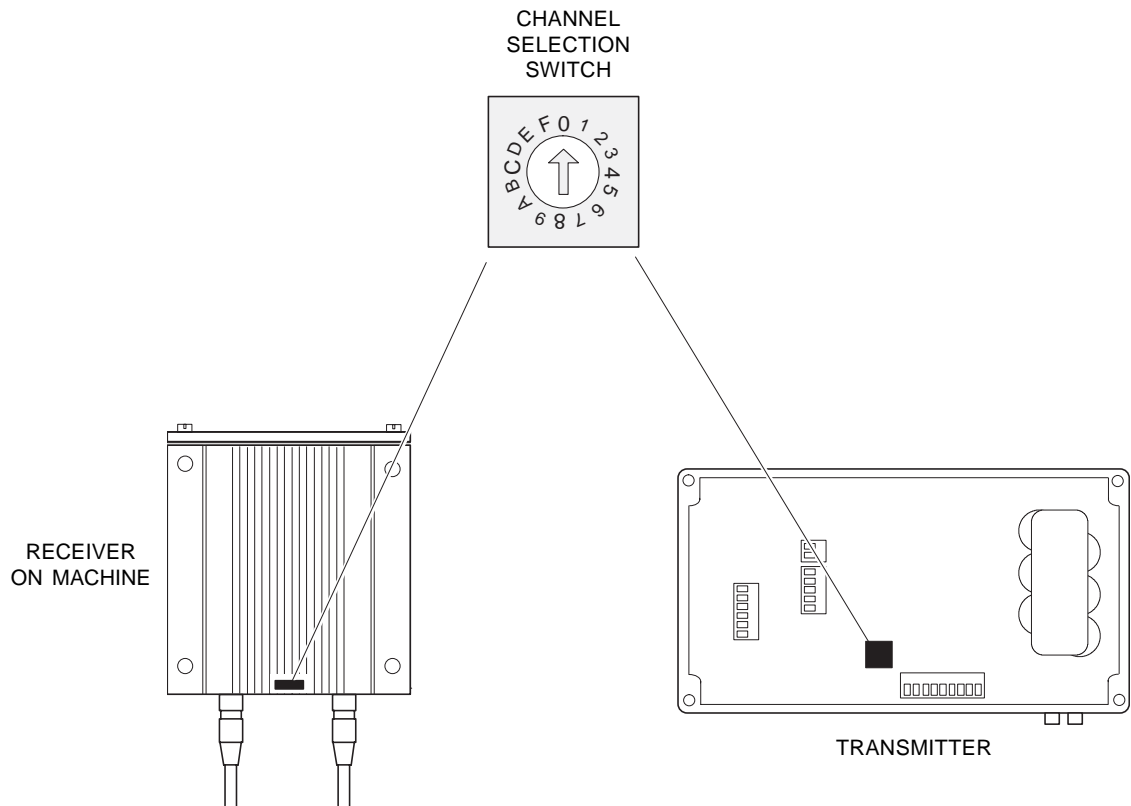

1002SD63

2.12 Setting Channel (Tuning Transmitter)

The remote control system can be tuned to 16 different frequencies. This allows two or more machines to operate in the same area without interference.

A channel selection switch is included in both the transmitter and the receiver on the machine. For operation of the remote control system **BOTH** switches must be set to the **SAME** channel.

To tune a transmitter to the receiver on the machine or check to determine which channel is selected:

1. Open the transmitter box by removing the four screws holding it together. Carefully lift off the top cover. The channel selector switch is located on the circuit board inside.
2. Set the Remote Control switch on the machine to the "REMOTE CONTROL" position.
3. Turn the ignition switch on the transmitter box to "ON".

4. Insert a small screwdriver into the slot provided on the channel selector switch and turn the switch until the "BAT" light on the machine goes on. The transmitter is now tuned to the receiver.

Make note of the channel selected and label both the transmitter and machine with the correct channel number.

2.13 Changing Channels

If a different channel than the one selected is desired, it will be necessary to reset the selector switch in both the transmitter and receiver. To access the selector switch in the receiver, remove the four slotted head screws from the receiver and lift the bottom plate off. Set the selector switch in both the receiver and the transmitter to the same channel. Replace covers and label transmitter and machine to indicate new channel selection.

2.14 Maintenance

All components for the remote control system are sealed and protected from moisture and vibration. Except for a periodic visual inspection of parts and wiring, and replacement of the transmitter batteries, no other maintenance to the system is required.

2.15 Cleaning Transmitter

Although the entire circuit board is encapsulated with a water resistant material to minimize water damage, direct contact with water should be avoided.

Like any electronic device, water can quickly damage the electronic circuits inside the transmitter. To clean the transmitter, wash off using a damp cloth and allow to dry.

Store the transmitter inside in a clean, dry area when the machine is not in use.

CAUTION

DO NOT immerse transmitter in water or rinse using a hose or pressure wash.

2.16 Pressure Washing Machine

When pressure washing machine, avoid spraying directly in area around control panel **(a)** and back cover **(b)**. Most of the machine's electronic circuitry is located in this area and could be damaged by a strong spray of water.

2.17 Replacing Transmitter Batteries

The battery pack inside the transmitter should be replaced once a year or as needed. To replace batteries, remove the four screws holding the transmitter together. Lift cover and carefully pull the battery connector from its socket.

Loosen the two small screws which secure the wires to the connector and pull wires free. Insert the two wire leads from the new battery pack and secure them in connector. Replace battery pack and close transmitter.

Be sure to observe the **correct polarity** when attaching battery wire leads or the transmitter will not operate.

Note: *New batteries may not be fully charged. After replacing batteries charge them overnight to ensure they are at full capacity.*

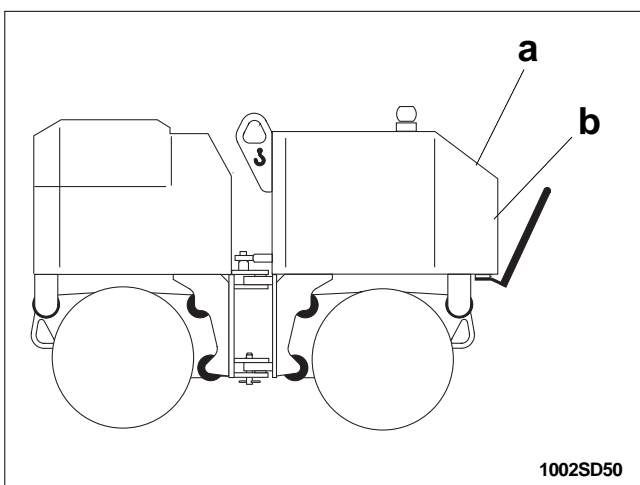

1002SD50

2.18 Troubleshooting

<p>TRANSMITTER NOT WORKING (Green LED off)</p>	<ol style="list-style-type: none"> 1. Transmitter battery low. 2. Ignition switch defective. 3. Battery connection loose. 4. Transmitter defective.
<p>TRANSMITTER WORKING BUT NO FUNCTIONS ON MACHINE (Remote control light off)</p>	<ol style="list-style-type: none"> 1. Selector switch not set to "REMOTE CONTROL". 2. Selector switch defective or connections loose. 3. Main fuse on engine wiring harness blown. 4. Machine battery dead. 5. Cable connections on receiver loose. 6. Plus (+) terminal on electronic relay loose or oxidized. 7. Incorrect channel. 8. Electronic relay faulty. 9. Receiver or sensing eye faulty.
<p>TRANSMITTER DOES NOT HAVE ENOUGH RANGE - LESS THAN 30 FT (10 M)</p>	<ol style="list-style-type: none"> 1. Transmitter battery charge low. 2. Transmitter window dirty. 3. Sensing eye dirty. 4. Sensing eye defective.
<p>TRANSMITTER AND RELAY WORKING BUT NO FUNCTIONS OPERATE (Green LED and remote control light on)</p>	<ol style="list-style-type: none"> 1. Channel selector switch in transmitter and receiver not matched. 2. Poor cable connections on receiver. 3. Receiver defective. 4. Sensing eye defective.
<p>ONE OR MORE FUNCTIONS INOPERATIVE</p>	<ol style="list-style-type: none"> 1. Defective switch or switches in transmitter. 2. Poor switch connections in transmitter. 3. Solenoid valve on machine defective. 4. Poor ground on solenoid. 5. Bad connection on relay terminal. 6. Interface faulty.
<p>TRANSMITTER AND REMOTE SYSTEM ON BUT ENGINE DOES NOT START</p>	<p>Refer to general Machine Troubleshooting on page 1-18.</p>

2.19 Relays and Engine Wiring Schematic
(W/15 Amp Vibration Relay Fuse)

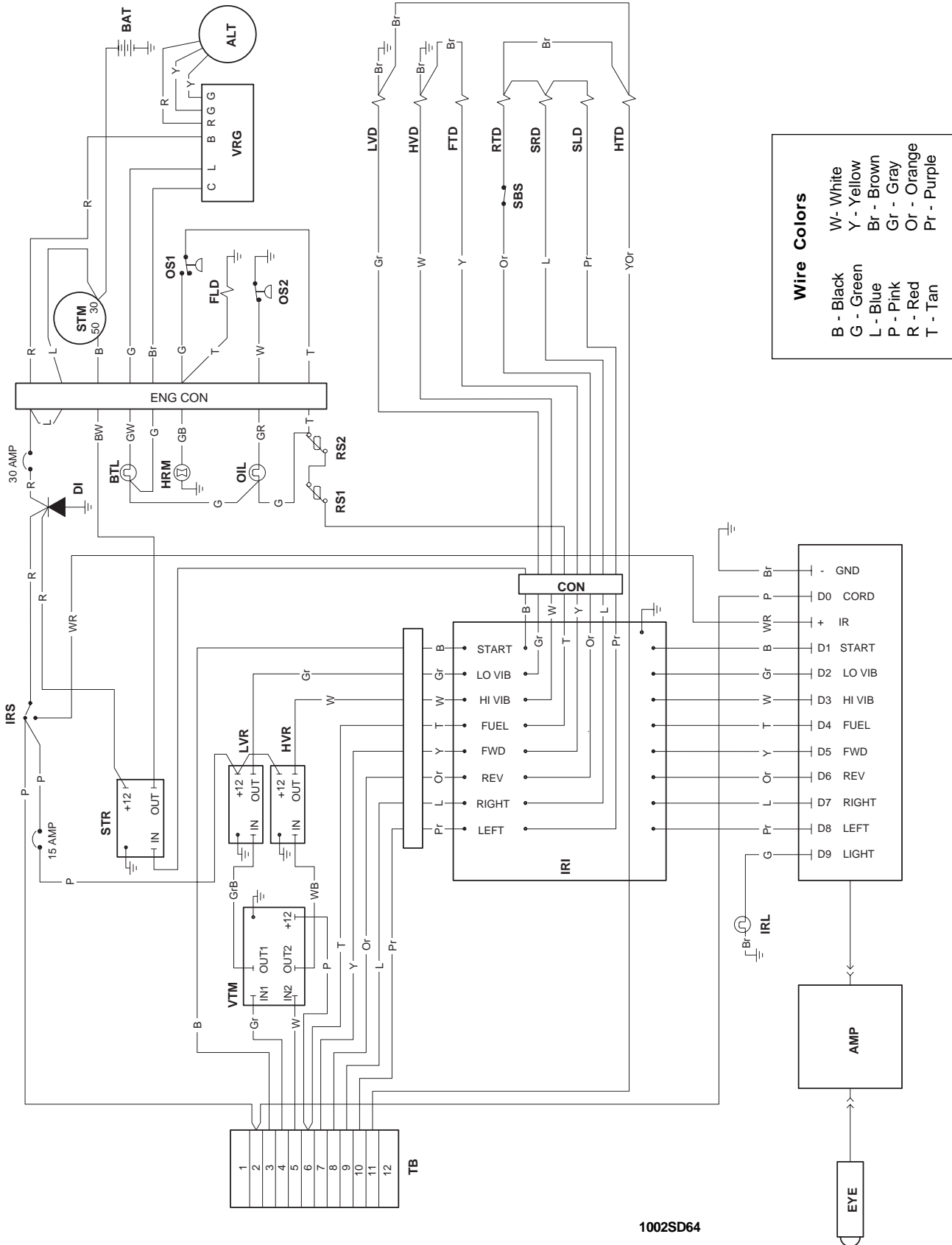

1002SD64

2.20 Transmitter Wiring Schematic

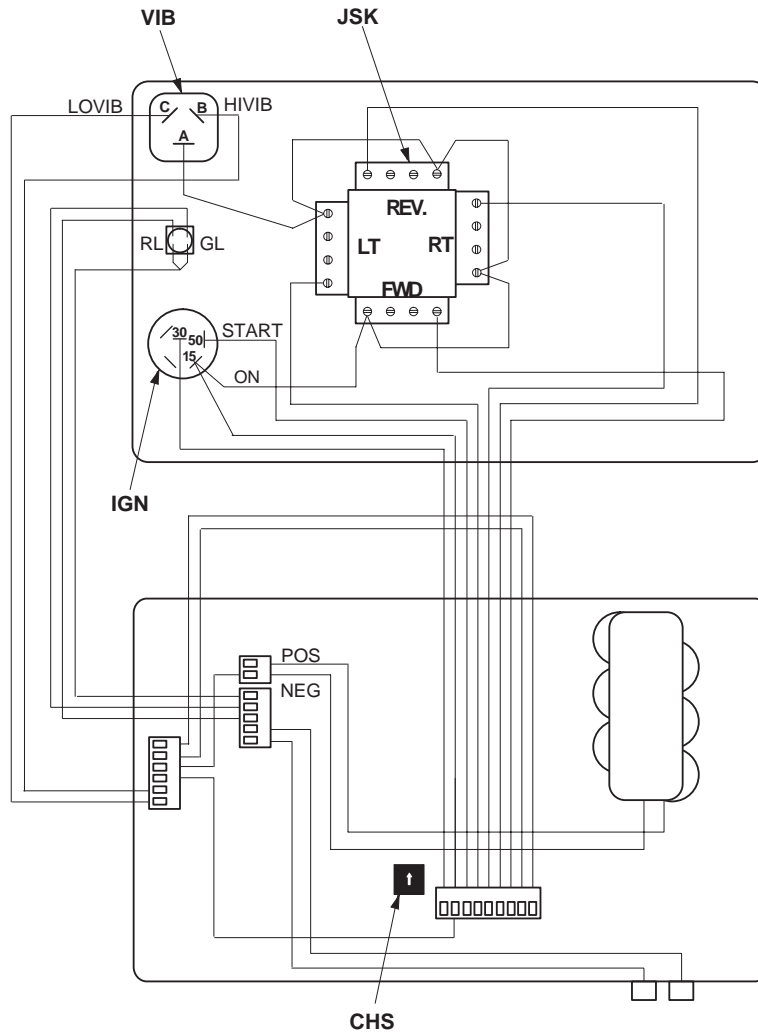

1002SD65

ALT	Alternator	HTD	High Speed Travel Solenoid	OS2	Oil Pressure Switch (7 psi)
AMP	Amplifier	HVD	High Vibration Solenoid	RS1	Rollover Switch (Left)
BAT	Battery (12V)	HVR	High Vibration Relay	RS2	Rollover Switch (Right)
BPK	Battery Pack (7.2V)	JSK	Joystick	RTD	Reverse Travel Solenoid
BTL	Battery Warning Light	IGN	Ignition Switch	SBS	Safety Bar Switch
CHS	Channel Selector Switch	IRI	Infra-red Interface	SLD	Steer Left Solenoid
CON	Connector	IRL	Infra-red Indicator Light	SRD	Steer Right Solenoid
DI	Diode	IRS	Infra-Red Switch	STM	Starter Motor
EYE	Infra-red Sensing Eye	LVD	Low Vibration Solenoid	STR	Starter Relay
FLD	Fuel Valve Solenoid	LVR	Low Vibration Relay	VIB	Vibration Switch
FTD	Forward Travel Solenoid	OIL	Oil Pressure Warning Light	VRG	Voltage Regulator
HRM	Hour Meter	OS1	Oil Pressure Switch (4 psi)	VTM	Vibration Timer

2.21 Relays and Engine Wiring Schematic

(W/O 15 Amp Vibration Relay Fuse)

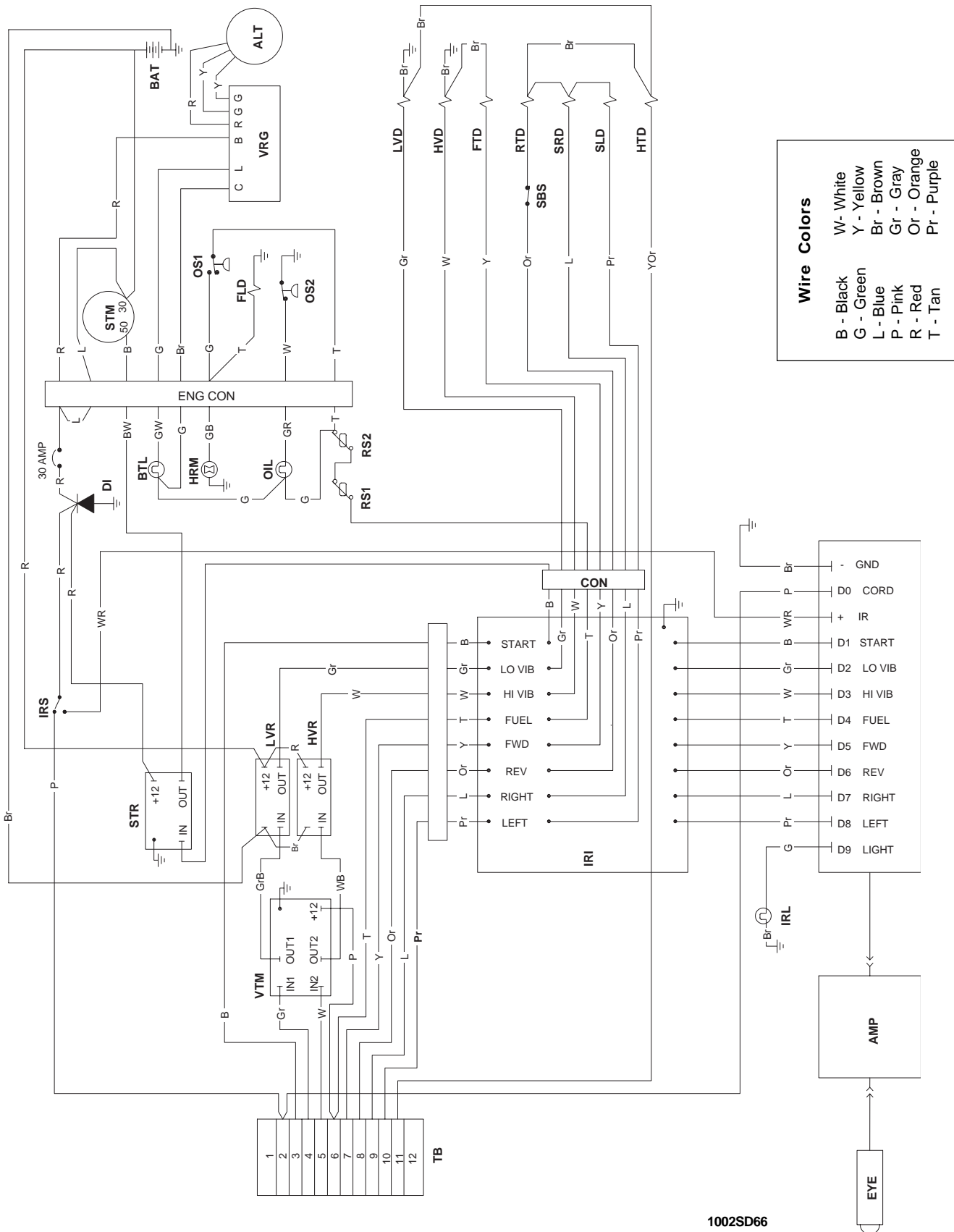



Use Of Threadlockers and Sealants

Threadlocking adhesives and sealants are specified throughout this manual and should be used where indicated. Threadlocking compounds normally break down at temperatures above 350° F (175° C). If a screw or bolt is hard to remove, heat it using a small propane torch to break down sealant. When applying sealants, follow instructions on container. The sealants listed below are recommended for use on WACKER equipment.

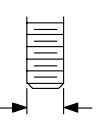
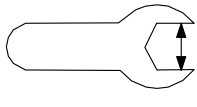

TYPE () = Europe	COLOR	USAGE	PART NO. - SIZE
Loctite 222 Hernon 420 Omnifit 1150 (50M)	Purple	Low strength, for locking threads smaller than 1/4" (6 mm). Hand tool removable. Temp. range, -65 to 300 degrees F (-54 to 149 degrees C)	73287 - 10 ml
Loctite 243 Hernon 423 Omnifit 1350 (100M)	Blue	Medium strength, for locking threads larger than 1/4" (6 mm). Hand tool removable. Temp. range, -65 to 300 degrees F (-54 to 149 degrees C)	29311 - .5 ml 17380 - 50 ml
Loctite 271 / 277 Hernon 427 Omnifit 1550 (220M)	Red	High strength, for all threads up to 1" (25 mm). Heat parts before disassembly. Temp. range, -65 to 300 degrees F (-54 to 149 degrees C)	29312 - .5 ml 26685 - 10 ml 73285 - 50 ml
Loctite 290 Hernon 431 Omnifit 1710 (230LL)	Green	Medium to high strength, for locking preassembled threads and for sealing weld porosity (wicking). Gaps up to 0.005" (0.13 mm) Temp. range, -65 to 300 degrees F (-54 to 149 degrees C)	28824 - .5 ml 25316 - 10 ml
Loctite 609 Hernon 822 Omnifit 1730 (230L)	Green	Medium strength retaining compound for slip or press fit of shafts, bearings, gears, pulleys, etc. Gaps up to 0.005" (0.13 mm) Temp. range, -65 to 300 degrees F (-54 to 149 degrees C)	29314 - .5 ml
Loctite 545 Hernon 947 Omnifit 1150 (50M)	Brown	Hydraulic sealant Temp. range, -65 to 300 degrees F (-54 to 149 degrees C)	79356 - 50 ml
Loctite 592 Hernon 920 Omnifit 790	White	Pipe sealant with Teflon for moderate pressures. Temp. range, -65 to 300 degrees F (-54 to 149 degrees C)	26695 - 6 ml 73289 - 50 ml
Loctite 515 Hernon 910 Omnifit 10	Purple	Form-in-place gasket for flexible joints. Fills gaps up to 0.05" (1.3 mm) Temp. range, -65 to 300 degrees F (-54 to 149 degrees C)	70735 - 50 ml
Loctite 496 Hernon 110 Omnifit Sicomet 7000	Clear	Instant adhesive for bonding rubber, metal and plastics; general purpose. For gaps up to 0.006" (0.15 mm) Read caution instructions before using. Temp. range, -65 to 180 degrees F (-54 to 82 degrees C)	52676 - 1 oz.
Loctite Primer T Hernon Primer 10 Omnifit VC Activator	Aerosol Spray	Fast curing primer for threadlocking, retaining and sealing compounds. Must be used with stainless steel hardware. Recommended for use with gasket sealants.	2006124 - 6 oz.

TORQUE VALUES

Metric Fasteners (DIN)

	TORQUE VALUES (Based on Bolt Size and Hardness)						WRENCH SIZE			
	8.8		10.9		12.9					
Size	Ft.Lb.	Nm	Ft.Lb.	Nm	Ft.Lbs.	Nm	Inch	Metric	Inch	Metric
M3	*11	1.2	*14	1.6	*19	2.1	7/32	5.5	-	2.5
M4	*26	2.9	*36	4.1	*43	4.9	9/32	7	-	3
M5	*53	6.0	6	8.5	7	10	5/16	8	-	4
M6	7	10	10	14	13	17	-	10	-	5
M8	18	25	26	35	30	41	1/2	13	-	6
M10	36	49	51	69	61	83	11/16	17	-	8
M12	63	86	88	120	107	145	3/4	19	-	10
M14	99	135	140	190	169	230	7/8	22	-	12
M16	155	210	217	295	262	355	15/16	24	-	14
M18	214	290	298	405	357	485	1-1/16	27	-	14
M20	302	410	427	580	508	690	1-1/4	30	-	17

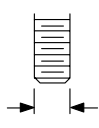
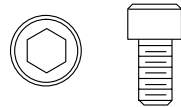
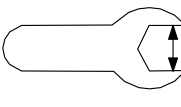
Inch Fasteners (SAE)

	SAE 5		SAE 8							
	Ft.Lb.	Nm	Ft.Lb.	Nm	Ft.Lbs.	Nm	Inch	Metric	Inch	Metric
No.4	*6	0.7	*14	1.0	*12	1.4	1/4	5.5	3/32	-
No.6	*12	1.4	*17	1.9	*21	2.4	5/16	8	7/64	-
No.8	*22	2.5	*31	3.5	*42	4.7	11/32	9	9/64	-
No.10	*32	3.6	*45	5.1	*60	6.8	3/8	-	5/32	-
1/4	6	8.1	9	12	12	16	7/16	-	3/32	-
5/16	13	18	19	26	24	33	1/2	13	1/4	-
3/8	23	31	33	45	43	58	9/16	-	5/16	-
7/16	37	50	52	71	69	94	5/8	16	3/8	-
1/2	57	77	80	109	105	142	3/4	19	3/8	-
9/16	82	111	115	156	158	214	13/16	-	-	-
5/8	112	152	159	216	195	265	15/16	24	1/2	-
3/4	200	271	282	383	353	479	1-1/8	-	5/8	-

1 Ft.Lb. = 1.357 Nm

* = In.Lb.

1 Inch = 25.4 mm